



## TECHNICAL GUIDE

### HORIZONTAL DISCHARGE SPLIT SYSTEM AIR CONDITIONERS

**14 SEER – R-410A – 1 PHASE  
2, 3, 4 NOMINAL TONS  
MODELS: TCHE24, 36, 48**

FOR INSTALLATION IN ALL US REGIONS AND CANADA



**Due to continuous product improvement, specifications are subject to change without notice.**

Visit us on the web at

[www.upgnet.com](http://www.upgnet.com) and [www.york.com](http://www.york.com)

Additional rating information can be found at

[www.ahridirectory.org](http://www.ahridirectory.org)

#### **WARRANTY SUMMARY\***

Extended 10-Years limited parts warranty.

Standard 10-Years limited compressor warranty.

**Extended 10-Years limited parts warranty** when product is registered online within 90 days of purchase for replacement or closing for new home construction.

\*Does not apply to 3-Phase models, or Internet sales.

See Limited Warranty certificate in User's Information Manual for details.

## DESCRIPTION

The 14 SEER TCHE Series condensing unit is the outdoor part of a versatile system of air conditioning. Optimized for the new 14 SEER Regional Minimum Efficiency and the high EER required in the Southwest US, these outdoor units are specifically designed to be matched with York indoor coils, furnaces, and air handlers to provide a complete system solution.

These remarkably compact units require only minimal service and airflow clearances, allowing them to be positioned as close as six inches (6") from the wall. This design allows the unit to be located virtually anywhere – on the ground, roof, balcony, or mounted to an outside wall. When installation footprint is limited, these units can be stacked two-high using the approved stacking kit.

## FEATURES

- **Performance** - Optimized for the US DOE Southwest Region and valid for installation in all US DOE Regions.
- **Small Footprint** - Compact "slim-line" design allows for easy installation in tight spaces. Units can be stacked two-high with approved stacking kit.
- **QuietDrive™ System** - The combination of a swept-wing fan, rigid base pan, isolated compressor compartment, and quiet scroll compressor reduce sound to as low as 70 dBA.
- **Low Operating Sound Levels** - The swept-wing condenser fan in blow-through configuration provides for whisper-quiet operation by allowing air to flow smoothly and efficiently across the fan blades.
- **Quality Condenser Coils** - The coil is constructed of aluminum microchannel tubing and enhanced aluminum fins for compact size and increased efficiency.
- **Environmentally Friendly Refrigerant** - The next generation refrigerant R-410A delivers environmentally friendly performance with zero ozone depletion.
- **Durable Cabinet** - Heavy-gauge steel cabinet and tubular base rails provide added support.
- **Aesthetic Appearance** - Powder paint "Champagne" color provides an attractive retail finish.
- **Agency Listed** - Safety certified by CSA to UL 1995 / CSA 22.2. Performance certified to ANSI/AHRI Standard 210/240 in accordance with the Unitary Small Equipment certification program.
- **Other Features:**
  - Factory installed spun copper filter drier
  - High pressure and low pressure switches
  - Accumulator and crankcase heater in all sizes
  - Up to 200' line set out of the box
  - Zero lot line - only 6" minimum clearance from structure

**LIST OF SECTIONS**

**DESCRIPTION** ..... 1  
**FEATURES** ..... 1  
**NOMENCLATURE** ..... 2  
**PHYSICAL AND ELECTRICAL DATA** ..... 3  
**SYSTEM CHARGE FOR VARIOUS MATCHED SYSTEMS** ..... 4  
**COOLING CAPACITY - With Air Handler Coils** ..... 5  
**COOLING CAPACITY - Upflow, Downflow & Horizontal Furnaces and Coils (Coil Only Ratings)** ..... 6  
**COOLING CAPACITY - With High Efficiency Motor Furnaces** ... 6  
**APPLICATIONS AND ACCESSORIES** ..... 12  
**SOUND POWER RATINGS** ..... 12  
**MECHANICAL SPECIFICATIONS** ..... 13  
**TYPICAL INSTALLATION** ..... 14  
**MOUNTING HOLE GRAPHIC** ..... 14  
**TYPICAL FIELD WIRING** ..... 14  
**PERFORMANCE DATA - 2 TON** ..... 15  
**PERFORMANCE DATA - 3 TON** ..... 18  
**PERFORMANCE DATA - 4 TON** ..... 20

**NOMENCLATURE**

<b>BRAND</b>	<b>T</b>	<b>T</b> = Factory Branded
<b>PRODUCT TYPE</b>	<b>C</b>	<b>C</b> = Air Conditioner (US Northern or Southeast Region)
<b>AIRFLOW</b>	<b>H</b>	<b>H</b> = Horizontal Discharge
<b>NOMINAL SERIES EFFICIENCY AND STAGING</b>	<b>E</b>	<b>E</b> = 14 SEER High EER (US DOE Southwest Region)
<b>NOMINAL UNIT CAPACITY (MBH)</b>	<b>36</b>	<b>24</b> = 2 Ton
		<b>36</b> = 3 Ton
		<b>48</b> = 4 Ton
<b>STAGING</b>	<b>S</b>	<b>S</b> = Single Stage Compressor
<b>REFRIGERANT</b>	<b>4</b>	<b>4</b> = R-410A Refrigerant
<b>VOLTAGE (Voltage-Phase-Hertz)</b>	<b>1</b>	<b>1</b> = 208/230-1-60
		<b>3</b> = 208/230-3-60
		<b>4</b> = 460-3-60
<b>CONNECTION TYPE</b>	<b>S</b>	<b>S</b> = Sweat Connect
<b>GENERATION (MAJOR REVISION)</b>	<b>1</b>	<b>1</b> = 1st Gen
		<b>2</b> = 2nd Gen
		etc
<b>STYLE LETTER (MINOR REVISION) NOT USED FOR ORDERING</b>	<b>A</b>	<b>A</b> = Style A
		<b>B</b> = Style B
		etc

## PHYSICAL AND ELECTRICAL DATA

MODEL		TCHE24S41S1	TCHE36S41S1	TCHE48S41S1
Unit Supply Voltage		208-230V, 1 $\phi$ , 60Hz		
Normal Voltage Range <sup>1</sup>		187 to 252		
Minimum Circuit Ampacity		18.3	19.1	24.6
Max. Overcurrent Device Amps <sup>2</sup>		30	30	40
Min. Overcurrent Device Amps <sup>3</sup>		20	20	25
Compressor Amps	Type	Scroll	Scroll	Scroll
	Rated Load	13.5	14.1	18.5
	Locked Rotor	58.3	72.2	124.0
Crankcase Heater		Yes	Yes	Yes
Factory External Discharge Muffler		No	No	No
Factory External Check Valve		No	No	No
HS Kit Required with TXV <sup>4</sup>		No	No	No
Fan Diameter Inches		23	23	23
Fan Motor	Rated HP	1/4	1/4	1/4
	Rated Load Amps	1.3	1.3	1.3
	Nominal RPM	850	850	850
	Nominal CFM	3200	3200	3050
Coil	Face Area Sq. Ft.	11.96	11.96	13.96
	Rows Deep	1	1	1
	Fins / Inch	23	23	23
Refrigerant Lines <sup>5</sup>	Max. Length	200	200	200
	Max. Lift	65	65	65
	Max. Drop	150	150	150
Liquid Line Set OD (Field Installed)		3/8	3/8	3/8
Vapor Line Set OD (Field Installed)		3/4	3/4	7/8
Unit Charge (Lbs. - Oz.) <sup>6</sup>		5 - 0	6 - 6	7 - 4
Charge Per Foot, Oz.		0.62	0.62	0.67
Operating Weight Lbs.		195	215	240

- Rated in accordance with AHRI Standard 110-2012, utilization range "A".
- Dual element fuses or HACR circuit breaker. Maximum allowable overcurrent protection.
- Dual element fuses or HACR circuit breaker. Minimum recommended overcurrent protection.
- See Hard Start Kit Accessory Installation Manual for Hard Start Kit part number for each model.
- When more than 50 feet of interconnecting tubing and more than 30 feet of vertical lift is used, consult the Application Data (part number 247077). For long-line applications, interconnecting lines over 100 feet must be installed with liquid line solenoid.
- The Unit Charge is correct for the outdoor unit, smallest matched indoor unit, and 15 feet of refrigerant tubing. For tubing lengths other than 15 feet, add or subtract the amount of refrigerant, using the difference in length multiplied by the per foot value.

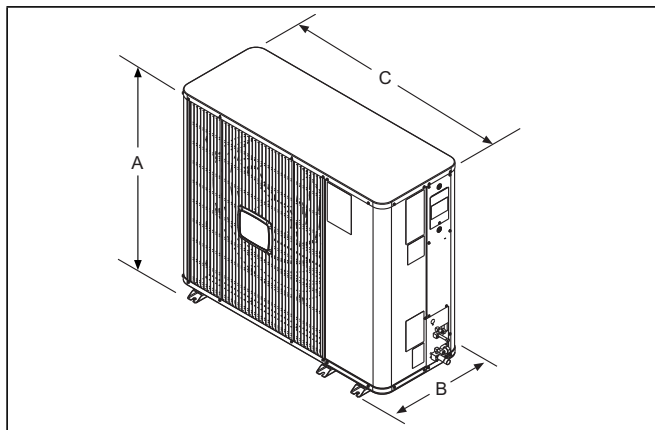

## DIMENSIONS

Unit Model	Dimensions (Inches)			Refrigerant Connection Service Valve Size	
	A	B	C	Liquid	Vapor
TCHE24S41S1	37-1/4	20	45	3/8	3/4
TCHE36S41S1	37-1/4	20	45		
TCHE48S41S1	43-1/4	20	45		7/8

All dimensions are in inches and are subject to change without notice.  
 Overall height is from bottom of mounting feet to top of unit.  
 Overall length and width include mounting feet and screw heads.

**SYSTEM CHARGE FOR VARIOUS MATCHED SYSTEMS**

<b>System Charge for Various Matched Systems</b>			
<b>Outdoor Unit</b>	<b>TCHE24S41S1</b>	<b>TCHE36S41S1</b>	<b>TCHE48S41S1</b>
<b>Required TXV <sup>1,2</sup></b>	BA1	BA2	BA2
<b>Indoor Unit <sup>3,4,5</sup></b>	<b>Additional Charge, Oz</b>		
CF/CM/CU30(B,C,D)	0	–	–
CF/CM/CU36(A,B,C,D)	7	–	–
FC38C	–	0	–
FC49D	–	–	0
AP30B	0	–	–
AP36C	7	–	–
AE30B	0	–	–
AE36(B,C)	7	–	–
AVC30B	0	–	–
AVC36(B,C)	7	–	–

Some of the combinations shown in the above System Charge table require Advanced Main Air Circulating Fan indoor product. For approved coil only matches, please see the "COOLING CAPACITY - Upflow, Downflow & Horizontal Furnaces and Coils" table.

**FOOTNOTES:**

1. For applications requiring a TXV use S1-1TVM\*\*\* series kit.
2. A TXV kit must be used with these indoor units to obtain system performance.
3. Systems matched with furnaces or air handlers not equipped with blower-off delays may require blower Time Delay Kit S1-2FD06700224.
4. CF and FC coils cannot be used in horizontal applications.
5. Refer to Cooling Performance Data tables for actual system performance for specified system matches.

**PROCEDURES:**

1. Unit factory charge listed on the unit nameplate includes refrigerant for the outdoor unit, the smallest matched indoor unit, and 15 feet of interconnecting line tubing.
2. Verify the TXV and additional charge required for specific matched indoor unit in the system using the above table.
3. Add additional charge for the amount of interconnecting line tubing greater than 15 feet at the rate specified in Physical and Electrical Data Table.
4. For indoor matches requiring additional charge, the refrigerant needs to be weighed in for specific matched indoor unit and lineset length.
5. Permanently mark the unit nameplate with the total system charge. Total System Charge = Base Charge (as shipped) + charge adder for matched indoor unit + charge adder for line set.

**COOLING CAPACITY - With Air Handler Coils**

UNIT MODEL	AIR HANDLER		COIL MODEL <sup>1</sup>	COOLING				
	MODEL	WIDTH		RATED CFM	NET MBH		SEER	EER
					TOTAL	SENS.		
TCHE24S41S	AE30BX21	17.5	—	800	24.0	18.5	15.50	12.75
TCHE24S41S	AE36BX21	17.5	—	800	24.0	18.7	15.75	13.00
TCHE24S41S	AE36CX21	21.0	—	800	24.0	18.7	16.00	13.00
TCHE24S41S	AP30BX21	17.5	—	800	23.8	18.5	14.00	12.25
TCHE24S41S	AVC30BX21	17.5	—	825	24.0	18.6	15.75	13.00
TCHE24S41S	AVC36BX21	17.5	—	800	24.0	18.7	16.00	13.00
TCHE24S41S	AVC36CX21	21.0	—	800	24.0	18.6	16.00	13.00
TCHE24S41S	ME08BN21	17.5	CF/CM30B	825	24.0	18.6	15.50	12.75
TCHE24S41S	ME08BN21	17.5	CF/CM36B	775	24.0	18.4	15.75	13.00
TCHE24S41S	ME12BN21	17.5	CF/CM30B	825	24.0	18.6	15.50	12.75
TCHE24S41S	ME12BN21	17.5	CF/CM36B	825	24.0	19.1	15.75	13.00
TCHE24S41S	ME14DN21	24.5	CF/CM30D	825	24.0	18.5	15.75	13.00
TCHE24S41S	ME14DN21	24.5	CF/CM36D	825	24.0	19.1	16.00	13.00
TCHE24S41S	ME16CN21	21.0	CF/CM30C	800	24.0	18.5	15.00	12.50
TCHE24S41S	ME16CN21	21.0	CF/CM36C	825	24.0	19.0	15.00	12.50
TCHE24S41S	MVC08BN21	17.5	CF/CM30B	725	24.0	18.0	15.75	13.00
TCHE24S41S	MVC08BN21	17.5	CF/CM36B	750	24.0	18.3	15.25	12.75
TCHE24S41S	MVC12BN21	17.5	CF/CM30B	775	24.0	18.4	15.25	12.75
TCHE24S41S	MVC12BN21	17.5	CF/CM36B	775	24.0	18.5	15.50	12.75
TCHE24S41S	MVC14DN21	24.5	CF/CM30D	750	24.0	18.0	15.50	12.75
TCHE24S41S	MVC14DN21	24.5	CF/CM36D	825	24.0	19.1	16.00	13.00
TCHE24S41S	MVC16CN21	21.0	CF/CM30C	850	24.0	19.0	15.00	12.50
TCHE24S41S	MVC16CN21	21.0	CF/CM36C	850	24.0	19.0	15.25	12.75
TCHE36S41S	ME16CN21	21.0	FC38C	1200	36.0	27.2	16.00	13.00
TCHE36S41S	MVC16CN21	21.0	FC38C	1200	35.8	27.2	15.50	12.75
TCHE48S41S	ME14DN21	24.5	FC49D	1425	46.5	34.6	15.10	12.50
TCHE48S41S	ME20DN21	24.5	FC49D	1425	46.5	34.6	15.50	12.50
TCHE48S41S	MVC14DN21	24.5	FC49D	1175	45.5	31.8	15.50	12.75
TCHE48S41S	MVC20DN21	24.5	FC49D	1375	46.5	34.2	15.50	12.75

Rated in accordance with DOE test procedures (Federal Register 12-27-79 and 3-18-88) and ANSI/AHRI Standard 210/240.

Cooling MBH based on 80°F entering air temperature, 50% RH (Relative Humidity), and rated air flow.

EER (Energy Efficiency Ratio) is the total cooling output in BTUs at 95°F outdoor ambient divided by the total electric power in watt-hours at those conditions.

SEER (Seasonal Energy Efficiency Ratio) is the total cooling output in BTUs during a normal annual usage period for cooling divided by the total electric power input in watt-hours during the same period.

1. CM coils available with a factory installed horizontal drain pan. See price pages for specific model number.

— = Not applicable.

MP Modular Air Handlers use Coil Only Ratings.

**COOLING CAPACITY - Upflow, Downflow & Horizontal Furnaces and Coils (Coil Only Ratings)**

UNIT MODEL	COIL		CFM RANGE (MIN.-MAX.)	COOLING				
	MODEL	WIDTH		RATED CFM	NET MBH		SEER <sup>1</sup>	EER
					TOTAL	SENS.		
TCHE24S41S	CF/CM/CU30B	17.5	600 - 1000	800	24.0	17.5	14.00	12.20
TCHE24S41S	CF/CM/CU30B	17.5	600 - 1000	800	24.0	17.5	14.00	12.20
TCHE24S41S	CF/CM/CU30C	21.0	600 - 1000	800	23.6	18.1	14.00	12.20
TCHE24S41S	CF/CM/CU30C	21.0	600 - 1000	800	23.6	18.1	14.00	12.20
TCHE24S41S	CF/CM/CU30D	24.5	600 - 1000	800	23.6	18.1	14.00	12.20
TCHE24S41S	CF/CM/CU30D	24.5	600 - 1000	800	23.6	18.1	14.00	12.20
TCHE24S41S	CF/CM36A	14.5	600 - 1000	800	23.6	18.3	14.00	12.20
TCHE24S41S	CF/CM36A	14.5	600 - 1000	800	23.6	18.3	14.00	12.20
TCHE24S41S	CF/CM/CU36B	17.5	600 - 1000	800	23.6	18.3	14.00	12.20
TCHE24S41S	CF/CM/CU36B	17.5	600 - 1000	800	23.6	18.3	14.00	12.20
TCHE24S41S	CF/CM/CU36C	21.0	600 - 1000	800	23.6	18.3	14.00	12.20
TCHE24S41S	CF/CM/CU36C	21.0	600 - 1000	800	23.6	18.3	14.00	12.20
TCHE24S41S	CF/CM/CU36D	24.5	600 - 1000	800	23.6	18.3	14.00	12.20
TCHE24S41S	CF/CM/CU36D	24.5	600 - 1000	800	23.6	18.3	14.00	12.20
TCHE24S41S	CF42B	17.5	600 - 1000	800	23.6	18.0	14.00	12.20
TCHE24S41S	CF42B	17.5	600 - 1000	800	23.6	18.0	14.00	12.20
TCHE36S41S	FC38C	21.0	1000 - 1400	1200	35.6	27.2	14.00	12.20
TCHE36S41S	FC38C	21.0	1000 - 1400	1200	35.6	27.2	14.00	12.20
TCHE48S41S	FC49D	21.0	1400 - 1800	1425	46.0	33.8	14.00	12.15
TCHE48S41S	FC49D	21.0	1400 - 1800	1425	46.0	33.8	14.00	12.15

For rated condition information, see the footnotes below the System Capacity - Single Piece and Modular Air Handlers table.

1. Requires a S1-2FD06700224 Blower Time Delay unless a standard furnace is equipped with one.

— = Not Applicable.

MP Modular Air Handlers use Coil Only Ratings.

PSC furnaces, such as the TG8S, TGLS, and TG9S, use Coil Only Ratings.

**COOLING CAPACITY - With High Efficiency Motor Furnaces<sup>1</sup>**

UNIT MODEL	FURNACE		COIL MODEL <sup>2</sup>	COOLING				
	MODEL	WIDTH		RATED CFM	NET MBH		SEER	EER
					TOTAL	SENS.		
TCHE24S41S	TM8V060A12MP11	14.5	CF/CM36A	775	24.0	18.5	15.25	12.75
TCHE24S41S	TM8V080B12MP11	17.5	CF/CM/CU30B	775	24.0	18.4	15.50	12.75
TCHE24S41S	TM8V080B12MP11	17.5	CF/CM/CU36B	775	24.0	18.5	15.50	12.75
TCHE24S41S	TM8V080C16MP11	21.0	CF/CM/CU30C	900	24.0	19.1	15.00	12.50
TCHE24S41S	TM8V080C16MP11	21.0	CF/CM/CU30D	900	24.0	19.1	15.00	12.50
TCHE24S41S	TM8V080C16MP11	21.0	CF/CM/CU36C	875	24.0	19.3	15.25	12.75
TCHE24S41S	TM8V080C16MP11	21.0	CF/CM/CU36D	900	24.0	19.5	15.25	12.75
TCHE24S41S	TM8V100C16MP11	21.0	CF/CM/CU30C	900	24.0	19.1	15.00	12.50
TCHE24S41S	TM8V100C16MP11	21.0	CF/CM/CU30D	900	24.0	19.1	15.00	12.50
TCHE24S41S	TM8V100C16MP11	21.0	CF/CM/CU36C	875	24.0	19.3	15.25	12.75
TCHE24S41S	TM8V100C16MP11	21.0	CF/CM/CU36D	900	24.0	19.5	15.25	12.75
TCHE24S41S	TM8X060A12MP11	14.5	CF/CM36A	775	24.0	18.5	15.50	12.75
TCHE24S41S	TM8X080B12MP11	17.5	CF/CM/CU30B	800	24.0	18.5	15.50	12.75
TCHE24S41S	TM8X080B12MP11	17.5	CF/CM/CU36B	800	24.0	18.7	15.75	13.00
TCHE24S41S	TM8X080C16MP11	21.0	CF/CM/CU30C	825	24.0	18.5	16.00	13.00
TCHE24S41S	TM8X080C16MP11	21.0	CF/CM/CU30D	825	24.0	18.5	16.00	13.00
TCHE24S41S	TM8X080C16MP11	21.0	CF/CM/CU36C	825	24.0	19.1	16.00	13.00
TCHE24S41S	TM8X080C16MP11	21.0	CF/CM/CU36D	825	24.0	19.1	16.00	13.00
TCHE24S41S	TM8X100C16MP11	21.0	CF/CM/CU30C	825	24.0	18.5	16.00	13.00

Continued on next page.

**COOLING CAPACITY - With High Efficiency Motor Furnaces<sup>1</sup> (Continued)**

UNIT MODEL	FURNACE		COIL MODEL <sup>2</sup>	COOLING				
	MODEL	WIDTH		RATED CFM	NET MBH		SEER	EER
					TOTAL	SENS.		
TCHE24S41S	TM8X100C16MP11	21.0	CF/CM/CU30D	825	24.0	18.5	16.00	13.00
TCHE24S41S	TM8X100C16MP11	21.0	CF/CM/CU36C	825	24.0	19.1	16.00	13.00
TCHE24S41S	TM8X100C16MP11	21.0	CF/CM/CU36D	825	24.0	19.1	16.00	13.00
TCHE24S41S	TM8X100C20MP11	21.0	CF/CM/CU30C	825	23.8	18.3	14.50	12.25
TCHE24S41S	TM8X100C20MP11	21.0	CF/CM/CU30D	825	24.0	18.5	14.50	12.25
TCHE24S41S	TM8X100C20MP11	21.0	CF/CM/CU36C	825	23.8	18.9	14.50	12.25
TCHE24S41S	TM8X100C20MP11	21.0	CF/CM/CU36D	825	24.0	19.1	14.50	12.25
TCHE24S41S	TM8X120C20MP11	21.0	CF/CM/CU30C	825	23.8	18.3	14.50	12.25
TCHE24S41S	TM8X120C20MP11	21.0	CF/CM/CU30D	825	24.0	18.5	14.50	12.25
TCHE24S41S	TM8X120C20MP11	21.0	CF/CM/CU36C	825	23.8	18.9	14.50	12.25
TCHE24S41S	TM8X120C20MP11	21.0	CF/CM/CU36D	825	24.0	19.1	14.50	12.25
TCHE24S41S	TM8Y060A12MP11	14.5	CF/CM36A	775	24.0	18.5	15.50	12.75
TCHE24S41S	TM8Y080B12MP11	17.5	CF/CM/CU30B	800	24.0	18.5	15.50	12.75
TCHE24S41S	TM8Y080B12MP11	17.5	CF/CM/CU36B	800	24.0	18.7	15.75	13.00
TCHE24S41S	TM8Y080C16MP11	21.0	CF/CM/CU30C	825	24.0	18.5	16.00	13.00
TCHE24S41S	TM8Y080C16MP11	21.0	CF/CM/CU30D	825	24.0	18.5	16.00	13.00
TCHE24S41S	TM8Y080C16MP11	21.0	CF/CM/CU36C	825	24.0	19.1	16.00	13.00
TCHE24S41S	TM8Y080C16MP11	21.0	CF/CM/CU36D	825	24.0	19.1	16.00	13.00
TCHE24S41S	TM8Y100C16MP11	21.0	CF/CM/CU30C	825	24.0	18.5	16.00	13.00
TCHE24S41S	TM8Y100C16MP11	21.0	CF/CM/CU30D	825	24.0	18.5	16.00	13.00
TCHE24S41S	TM8Y100C16MP11	21.0	CF/CM/CU36C	825	24.0	19.1	16.00	13.00
TCHE24S41S	TM8Y100C16MP11	21.0	CF/CM/CU36D	825	24.0	19.1	16.00	13.00
TCHE24S41S	TM8Y100C20MP11	21.0	CF/CM/CU30C	825	23.8	18.3	14.50	12.25
TCHE24S41S	TM8Y100C20MP11	21.0	CF/CM/CU30D	825	24.0	18.5	14.50	12.25
TCHE24S41S	TM8Y100C20MP11	21.0	CF/CM/CU36C	825	23.8	18.9	14.50	12.25
TCHE24S41S	TM8Y100C20MP11	21.0	CF/CM/CU36D	825	24.0	19.1	14.50	12.25
TCHE24S41S	TM8Y120C20MP11	21.0	CF/CM/CU30C	825	23.8	18.3	14.50	12.25
TCHE24S41S	TM8Y120C20MP11	21.0	CF/CM/CU30D	825	24.0	18.5	14.50	12.25
TCHE24S41S	TM8Y120C20MP11	21.0	CF/CM/CU36C	825	23.8	18.9	14.50	12.25
TCHE24S41S	TM8Y120C20MP11	21.0	CF/CM/CU36D	825	24.0	19.1	14.50	12.25
TCHE24S41S	TM9E040A10MP11	14.5	CF/CM36A	775	24.0	18.4	14.75	12.50
TCHE24S41S	TM9E060B12MP11	17.5	CF/CM/CU30B	800	24.0	18.5	14.75	12.25
TCHE24S41S	TM9E060B12MP11	17.5	CF/CM/CU36B	825	24.0	19.1	14.75	12.25
TCHE24S41S	TM9E080B12MP11	17.5	CF/CM/CU30B	800	24.0	18.5	14.75	12.25
TCHE24S41S	TM9E080B12MP11	17.5	CF/CM/CU36B	825	24.0	19.1	14.75	12.25
TCHE24S41S	TM9E080C16MP11	21.0	CF/CM/CU30C	750	24.0	18.0	16.00	13.00
TCHE24S41S	TM9E080C16MP11	21.0	CF/CM/CU30D	775	24.0	18.4	16.00	13.00
TCHE24S41S	TM9E080C16MP11	21.0	CF/CM/CU36C	750	24.0	18.2	16.00	13.00
TCHE24S41S	TM9E080C16MP11	21.0	CF/CM/CU36D	775	24.0	18.4	16.00	13.00
TCHE24S41S	TM9E100C16MP11	21.0	CF/CM/CU30C	750	24.0	18.0	16.00	13.00
TCHE24S41S	TM9E100C16MP11	21.0	CF/CM/CU30D	775	24.0	18.4	16.00	13.00
TCHE24S41S	TM9E100C16MP11	21.0	CF/CM/CU36C	750	24.0	18.2	16.00	13.00
TCHE24S41S	TM9E100C16MP11	21.0	CF/CM/CU36D	775	24.0	18.4	16.00	13.00
TCHE24S41S	TM9E100C20MP11	21.0	CF/CM/CU30C	800	24.0	18.5	15.00	12.50
TCHE24S41S	TM9E100C20MP11	21.0	CF/CM/CU30D	800	24.0	18.5	15.00	12.50
TCHE24S41S	TM9E100C20MP11	21.0	CF/CM/CU36C	800	24.0	18.6	15.00	12.50
TCHE24S41S	TM9E100C20MP11	21.0	CF/CM/CU36D	800	24.0	18.6	15.00	12.50
TCHE24S41S	TM9E120D20MP11	24.5	CF/CM/CU30D	825	24.0	18.6	15.25	12.75
TCHE24S41S	TM9E120D20MP11	24.5	CF/CM/CU36D	825	24.0	19.1	15.25	12.75
TCHE24S41S	TM9V060B12MP11	17.5	CF/CM/CU30B	800	24.0	18.5	15.25	12.75
TCHE24S41S	TM9V060B12MP11	17.5	CF/CM/CU36B	825	24.0	19.1	15.50	12.75
TCHE24S41S	TM9V080B12MP11	17.5	CF/CM/CU30B	800	24.0	18.5	15.25	12.75
TCHE24S41S	TM9V080B12MP11	17.5	CF/CM/CU36B	825	24.0	19.1	15.50	12.75

Continued on next page.

**COOLING CAPACITY - With High Efficiency Motor Furnaces<sup>1</sup> (Continued)**

UNIT MODEL	FURNACE		COIL MODEL <sup>2</sup>	COOLING				
	MODEL	WIDTH		RATED CFM	NET MBH		SEER	EER
					TOTAL	SENS.		
TCHE24S41S	TM9V080C16MP11	21.0	CF/CM/CU30C	850	24.0	19.0	15.50	12.75
TCHE24S41S	TM9V080C16MP11	21.0	CF/CM/CU30D	825	24.0	18.6	15.75	13.00
TCHE24S41S	TM9V080C16MP11	21.0	CF/CM/CU36C	850	24.0	19.1	15.50	12.75
TCHE24S41S	TM9V080C16MP11	21.0	CF/CM/CU36D	825	24.0	19.1	16.00	13.00
TCHE24S41S	TM9V100C16MP11	21.0	CF/CM/CU30C	850	24.0	19.0	15.50	12.75
TCHE24S41S	TM9V100C16MP11	21.0	CF/CM/CU30D	825	24.0	18.6	15.75	13.00
TCHE24S41S	TM9V100C16MP11	21.0	CF/CM/CU36C	850	24.0	19.1	15.50	12.75
TCHE24S41S	TM9V100C16MP11	21.0	CF/CM/CU36D	825	24.0	19.1	16.00	13.00
TCHE24S41S	TM9Y040A10MP11	14.5	CF/CM36A	775	24.0	18.4	14.75	12.50
TCHE24S41S	TM9Y060B12MP11	17.5	CF/CM/CU30B	800	24.0	18.5	14.75	12.25
TCHE24S41S	TM9Y060B12MP11	17.5	CF/CM/CU36B	825	24.0	19.1	14.75	12.25
TCHE24S41S	TM9Y080B12MP11	17.5	CF/CM/CU30B	800	24.0	18.5	14.75	12.25
TCHE24S41S	TM9Y080B12MP11	17.5	CF/CM/CU36B	825	24.0	19.1	14.75	12.25
TCHE24S41S	TM9Y080C16MP11	21.0	CF/CM/CU30C	750	24.0	18.0	16.00	13.00
TCHE24S41S	TM9Y080C16MP11	21.0	CF/CM/CU30D	775	24.0	18.4	16.00	13.00
TCHE24S41S	TM9Y080C16MP11	21.0	CF/CM/CU36C	750	24.0	18.2	16.00	13.00
TCHE24S41S	TM9Y080C16MP11	21.0	CF/CM/CU36D	775	24.0	18.4	16.00	13.00
TCHE24S41S	TM9Y100C16MP11	21.0	CF/CM/CU30C	750	24.0	18.0	16.00	13.00
TCHE24S41S	TM9Y100C16MP11	21.0	CF/CM/CU30D	775	24.0	18.4	16.00	13.00
TCHE24S41S	TM9Y100C16MP11	21.0	CF/CM/CU36C	750	24.0	18.2	16.00	13.00
TCHE24S41S	TM9Y100C16MP11	21.0	CF/CM/CU36D	775	24.0	18.4	16.00	13.00
TCHE24S41S	TM9Y100C20MP11	21.0	CF/CM/CU30C	800	24.0	18.5	15.00	12.50
TCHE24S41S	TM9Y100C20MP11	21.0	CF/CM/CU30D	800	24.0	18.5	15.00	12.50
TCHE24S41S	TM9Y100C20MP11	21.0	CF/CM/CU36C	800	24.0	18.6	15.00	12.50
TCHE24S41S	TM9Y100C20MP11	21.0	CF/CM/CU36D	800	24.0	18.6	15.00	12.50
TCHE24S41S	TM9Y120D20MP11	24.5	CF/CM/CU30D	825	24.0	18.6	15.25	12.75
TCHE24S41S	TM9Y120D20MP11	24.5	CF/CM/CU36D	825	24.0	19.1	15.25	12.75
TCHE24S41S	TMLV060A12MP11	14.5	CF/CM36A	775	24.0	18.5	15.25	12.75
TCHE24S41S	TMLV080B12MP11	17.5	CF/CM/CU30B	775	24.0	18.4	15.50	12.75
TCHE24S41S	TMLV080B12MP11	17.5	CF/CM/CU36B	775	24.0	18.5	15.50	12.75
TCHE24S41S	TMLV080C16MP11	21.0	CF/CM/CU30C	900	24.0	19.1	15.00	12.50
TCHE24S41S	TMLV080C16MP11	21.0	CF/CM/CU30D	900	24.0	19.1	15.00	12.50
TCHE24S41S	TMLV080C16MP11	21.0	CF/CM/CU36C	875	24.0	19.3	15.25	12.75
TCHE24S41S	TMLV080C16MP11	21.0	CF/CM/CU36D	900	24.0	19.5	15.25	12.75
TCHE24S41S	TMLV100C16MP11	21.0	CF/CM/CU30C	900	24.0	19.1	15.00	12.50
TCHE24S41S	TMLV100C16MP11	21.0	CF/CM/CU30D	900	24.0	19.1	15.00	12.50
TCHE24S41S	TMLV100C16MP11	21.0	CF/CM/CU36C	875	24.0	19.3	15.25	12.75
TCHE24S41S	TMLV100C16MP11	21.0	CF/CM/CU36D	900	24.0	19.5	15.25	12.75
TCHE24S41S	TMLX060A12MP11	14.5	CF/CM36A	775	24.0	18.5	15.50	12.75
TCHE24S41S	TMLX080B12MP11	17.5	CF/CM/CU30B	800	24.0	18.5	15.50	12.75
TCHE24S41S	TMLX080B12MP11	17.5	CF/CM/CU36B	800	24.0	18.7	15.75	13.00
TCHE24S41S	TMLX080C16MP11	21.0	CF/CM/CU30C	825	24.0	18.5	16.00	13.00
TCHE24S41S	TMLX080C16MP11	21.0	CF/CM/CU30D	825	24.0	18.5	16.00	13.00
TCHE24S41S	TMLX080C16MP11	21.0	CF/CM/CU36C	825	24.0	19.1	16.00	13.00
TCHE24S41S	TMLX080C16MP11	21.0	CF/CM/CU36D	825	24.0	19.1	16.00	13.00
TCHE24S41S	TMLX100C16MP11	21.0	CF/CM/CU30C	825	24.0	18.5	16.00	13.00
TCHE24S41S	TMLX100C16MP11	21.0	CF/CM/CU30D	825	24.0	18.5	16.00	13.00
TCHE24S41S	TMLX100C16MP11	21.0	CF/CM/CU36C	825	24.0	19.1	16.00	13.00
TCHE24S41S	TMLX100C16MP11	21.0	CF/CM/CU36D	825	24.0	19.1	16.00	13.00
TCHE24S41S	TMLX100C20MP11	21.0	CF/CM/CU30C	825	23.8	18.3	14.50	12.25
TCHE24S41S	TMLX100C20MP11	21.0	CF/CM/CU30D	825	24.0	18.5	14.50	12.25
TCHE24S41S	TMLX100C20MP11	21.0	CF/CM/CU36C	825	23.8	18.9	14.50	12.25

Continued on next page.



**COOLING CAPACITY - With High Efficiency Motor Furnaces<sup>1</sup> (Continued)**

UNIT MODEL	FURNACE		COIL MODEL <sup>2</sup>	COOLING				
	MODEL	WIDTH		RATED CFM	NET MBH		SEER	EER
					TOTAL	SENS.		
TCHE24S41S	TMLX100C20MP11	21.0	CF/CM/CU36D	825	24.0	19.1	14.50	12.25
TCHE24S41S	TMLX120C20MP11	21.0	CF/CM/CU30C	825	23.8	18.3	14.50	12.25
TCHE24S41S	TMLX120C20MP11	21.0	CF/CM/CU30D	825	24.0	18.5	14.50	12.25
TCHE24S41S	TMLX120C20MP11	21.0	CF/CM/CU36C	825	23.8	18.9	14.50	12.25
TCHE24S41S	TMLX120C20MP11	21.0	CF/CM/CU36D	825	24.0	19.1	14.50	12.25
TCHE24S41S	TP9C060B12MP12	17.5	CF/CM/CU30B	800	24.0	18.5	15.25	12.75
TCHE24S41S	TP9C060B12MP12	17.5	CF/CM/CU36B	825	24.0	19.1	15.50	12.75
TCHE24S41S	TP9C080B12MP12	17.5	CF/CM/CU30B	800	24.0	18.5	15.25	12.75
TCHE24S41S	TP9C080B12MP12	17.5	CF/CM/CU36B	825	24.0	19.1	15.50	12.75
TCHE24S41S	TP9C080C16MP12	21.0	CF/CM/CU30C	850	24.0	19.0	15.50	12.75
TCHE24S41S	TP9C080C16MP12	21.0	CF/CM/CU30D	825	24.0	18.6	15.75	13.00
TCHE24S41S	TP9C080C16MP12	21.0	CF/CM/CU36C	850	24.0	19.1	15.50	12.75
TCHE24S41S	TP9C080C16MP12	21.0	CF/CM/CU36D	825	24.0	19.1	16.00	13.00
TCHE24S41S	TP9C100C16MP12	21.0	CF/CM/CU30C	850	24.0	19.0	15.50	12.75
TCHE24S41S	TP9C100C16MP12	21.0	CF/CM/CU30D	825	24.0	18.6	15.75	13.00
TCHE24S41S	TP9C100C16MP12	21.0	CF/CM/CU36C	850	24.0	19.1	15.50	12.75
TCHE24S41S	TP9C100C16MP12	21.0	CF/CM/CU36D	825	24.0	19.1	16.00	13.00
TCHE24S41S	TPLC060A12MP12	14.5	CF/CM36A	775	24.0	18.5	15.25	12.75
TCHE24S41S	TPLC080B12MP12	17.5	CF/CM/CU30B	775	24.0	18.4	15.50	12.75
TCHE24S41S	TPLC080B12MP12	17.5	CF/CM/CU36B	775	24.0	18.5	15.50	12.75
TCHE24S41S	TPLC080C16MP12	21.0	CF/CM/CU30C	900	24.0	19.1	15.00	12.50
TCHE24S41S	TPLC080C16MP12	21.0	CF/CM/CU30D	900	24.0	19.1	15.00	12.50
TCHE24S41S	TPLC080C16MP12	21.0	CF/CM/CU36C	875	24.0	19.3	15.25	12.75
TCHE24S41S	TPLC080C16MP12	21.0	CF/CM/CU36D	900	24.0	19.5	15.25	12.75
TCHE24S41S	TPLC100C16MP12	21.0	CF/CM/CU30C	900	24.0	19.1	15.00	12.50
TCHE24S41S	TPLC100C16MP12	21.0	CF/CM/CU30D	900	24.0	19.1	15.00	12.50
TCHE24S41S	TPLC100C16MP12	21.0	CF/CM/CU36C	875	24.0	19.3	15.25	12.75
TCHE24S41S	TPLC100C16MP12	21.0	CF/CM/CU36D	900	24.0	19.5	15.25	12.75
TCHE24S41S	YP9C060B12MP12	17.5	CF/CM/CU30B	800	24.0	18.5	15.25	12.75
TCHE24S41S	YP9C060B12MP12	17.5	CF/CM/CU36B	825	24.0	19.1	15.50	12.75
TCHE24S41S	YP9C080B12MP12	17.5	CF/CM/CU30B	800	24.0	18.5	15.25	12.75
TCHE24S41S	YP9C080B12MP12	17.5	CF/CM/CU36B	825	24.0	19.1	15.50	12.75
TCHE24S41S	YP9C080C16MP12	21.0	CF/CM/CU30C	850	24.0	19.0	15.50	12.75
TCHE24S41S	YP9C080C16MP12	21.0	CF/CM/CU30D	825	24.0	18.6	15.75	13.00
TCHE24S41S	YP9C080C16MP12	21.0	CF/CM/CU36C	850	24.0	19.1	15.50	12.75
TCHE24S41S	YP9C080C16MP12	21.0	CF/CM/CU36D	825	24.0	19.1	16.00	13.00
TCHE24S41S	YP9C100C16MP12	21.0	CF/CM/CU30C	850	24.0	19.0	15.50	12.75
TCHE24S41S	YP9C100C16MP12	21.0	CF/CM/CU30D	825	24.0	18.6	15.75	13.00
TCHE24S41S	YP9C100C16MP12	21.0	CF/CM/CU36C	850	24.0	19.1	15.50	12.75
TCHE24S41S	YP9C100C16MP12	21.0	CF/CM/CU36D	825	24.0	19.1	16.00	13.00
TCHE24S41S	YPLC060A12MP12	14.5	CF/CM36A	775	24.0	18.5	15.25	12.75
TCHE24S41S	YPLC080B12MP12	17.5	CF/CM/CU30B	775	24.0	18.4	15.50	12.75
TCHE24S41S	YPLC080B12MP12	17.5	CF/CM/CU36B	775	24.0	18.5	15.50	12.75
TCHE24S41S	YPLC080C16MP12	21.0	CF/CM/CU30C	900	24.0	19.1	15.00	12.50
TCHE24S41S	YPLC080C16MP12	21.0	CF/CM/CU30D	900	24.0	19.1	15.00	12.50
TCHE24S41S	YPLC080C16MP12	21.0	CF/CM/CU36C	875	24.0	19.3	15.25	12.75
TCHE24S41S	YPLC080C16MP12	21.0	CF/CM/CU36D	900	24.0	19.5	15.25	12.75
TCHE24S41S	YPLC100C16MP12	21.0	CF/CM/CU30C	900	24.0	19.1	15.00	12.50
TCHE24S41S	YPLC100C16MP12	21.0	CF/CM/CU30D	900	24.0	19.1	15.00	12.50
TCHE24S41S	YPLC100C16MP12	21.0	CF/CM/CU36C	875	24.0	19.3	15.25	12.75
TCHE24S41S	YPLC100C16MP12	21.0	CF/CM/CU36D	900	24.0	19.5	15.25	12.75

Continued on next page.

**COOLING CAPACITY - With High Efficiency Motor Furnaces<sup>1</sup> (Continued)**

UNIT MODEL	FURNACE		COIL MODEL <sup>2</sup>	COOLING				
	MODEL	WIDTH		RATED CFM	NET MBH		SEER	EER
					TOTAL	SENS.		
TCHE36S41S	TM8V080C16MP11	21.0	FC38C	1200	35.6	27.0	15.10	12.50
TCHE36S41S	TM8V100C16MP11	21.0	FC38C	1200	35.6	27.0	15.10	12.50
TCHE36S41S	TM8V100C20MP11	21.0	FC38C	1150	35.8	26.8	15.50	13.00
TCHE36S41S	TM8V120C20MP11	21.0	FC38C	1150	35.8	26.8	15.50	13.00
TCHE36S41S	TM8X080C16MP11	21.0	FC38C	1200	35.8	27.2	15.50	12.75
TCHE36S41S	TM8X100C16MP11	21.0	FC38C	1200	35.8	27.2	15.50	12.75
TCHE36S41S	TM8X100C20MP11	21.0	FC38C	1200	35.6	27.0	15.25	12.75
TCHE36S41S	TM8X120C20MP11	21.0	FC38C	1200	35.6	27.0	15.25	12.75
TCHE36S41S	TM8Y080C16MP11	21.0	FC38C	1200	35.8	27.2	15.50	12.75
TCHE36S41S	TM8Y100C16MP11	21.0	FC38C	1200	35.8	27.2	15.50	12.75
TCHE36S41S	TM8Y100C20MP11	21.0	FC38C	1200	35.6	27.0	15.25	12.75
TCHE36S41S	TM8Y120C20MP11	21.0	FC38C	1200	35.6	27.0	15.25	12.75
TCHE36S41S	TM9E080C16MP11	21.0	FC38C	1200	35.6	27.0	15.25	12.75
TCHE36S41S	TM9E100C16MP11	21.0	FC38C	1200	35.6	27.0	15.25	12.75
TCHE36S41S	TM9E100C20MP11	21.0	FC38C	1200	35.6	27.0	15.25	12.75
TCHE36S41S	TM9V080C16MP11	21.0	FC38C	1175	35.8	27.0	15.50	12.75
TCHE36S41S	TM9V100C16MP11	21.0	FC38C	1175	35.8	27.0	15.50	12.75
TCHE36S41S	TM9V100C20MP11	21.0	FC38C	1200	35.6	27.0	15.25	12.75
TCHE36S41S	TM9Y080C16MP11	21.0	FC38C	1200	35.6	27.0	15.25	12.75
TCHE36S41S	TM9Y100C16MP11	21.0	FC38C	1200	35.6	27.0	15.25	12.75
TCHE36S41S	TM9Y100C20MP11	21.0	FC38C	1200	35.6	27.0	15.25	12.75
TCHE36S41S	TMLV080C16MP11	21.0	FC38C	1200	35.6	27.0	15.10	12.50
TCHE36S41S	TMLV100C16MP11	21.0	FC38C	1200	35.6	27.0	15.10	12.50
TCHE36S41S	TMLV100C20MP11	21.0	FC38C	1150	35.8	26.8	15.50	13.00
TCHE36S41S	TMLV120C20MP11	21.0	FC38C	1150	35.8	26.8	15.50	13.00
TCHE36S41S	TMLX080C16MP11	21.0	FC38C	1200	35.8	27.2	15.50	12.75
TCHE36S41S	TMLX100C16MP11	21.0	FC38C	1200	35.8	27.2	15.50	12.75
TCHE36S41S	TMLX100C20MP11	21.0	FC38C	1200	35.6	27.0	15.25	12.75
TCHE36S41S	TMLX120C20MP11	21.0	FC38C	1200	35.6	27.0	15.25	12.75
TCHE36S41S	TP9C080C16MP12	21.0	FC38C	1175	35.8	27.0	15.50	12.75
TCHE36S41S	TP9C100C16MP12	21.0	FC38C	1175	35.8	27.0	15.50	12.75
TCHE36S41S	TP9C100C20MP12	21.0	FC38C	1200	35.6	27.0	15.25	12.75
TCHE36S41S	TPLC080C16MP12	21.0	FC38C	1200	35.6	27.0	15.10	12.50
TCHE36S41S	TPLC100C16MP12	21.0	FC38C	1200	35.6	27.0	15.10	12.50
TCHE36S41S	TPLC100C20MP12	21.0	FC38C	1150	35.8	26.8	15.50	13.00
TCHE36S41S	TPLC120C20MP12	21.0	FC38C	1150	35.8	26.8	15.50	13.00
TCHE36S41S	YP9C080C16MP12	21.0	FC38C	1175	35.8	27.0	15.50	12.75
TCHE36S41S	YP9C100C16MP12	21.0	FC38C	1175	35.8	27.0	15.50	12.75
TCHE36S41S	YP9C100C20MP12	21.0	FC38C	1200	35.6	27.0	15.25	12.75
TCHE36S41S	YPLC080C16MP12	21.0	FC38C	1200	35.6	27.0	15.10	12.50
TCHE36S41S	YPLC100C16MP12	21.0	FC38C	1200	35.6	27.0	15.10	12.50
TCHE36S41S	YPLC100C20MP12	21.0	FC38C	1150	35.8	26.8	15.50	13.00
TCHE36S41S	YPLC120C20MP12	21.0	FC38C	1150	35.8	26.8	15.50	13.00
TCHE48S41S	TM8V080C16MP11	21.0	FC49D	1425	46.0	34.4	14.25	12.00
TCHE48S41S	TM8V100C16MP11	21.0	FC49D	1425	46.0	34.4	14.25	12.00
TCHE48S41S	TM8V100C20MP11	21.0	FC49D	1425	46.0	34.2	15.00	12.50
TCHE48S41S	TM8V120C20MP11	21.0	FC49D	1425	46.0	34.2	15.00	12.50
TCHE48S41S	TM8X080C16MP11	21.0	FC49D	1400	46.0	34.0	14.75	12.25
TCHE48S41S	TM8X100C16MP11	21.0	FC49D	1400	46.0	34.0	14.75	12.25
TCHE48S41S	TM8X100C20MP11	21.0	FC49D	1425	46.5	34.6	15.10	12.50
TCHE48S41S	TM8X120C20MP11	21.0	FC49D	1425	46.5	34.6	15.10	12.50
TCHE48S41S	TM8Y080C16MP11	21.0	FC49D	1400	46.0	34.0	14.75	12.25

Continued on next page.

**COOLING CAPACITY - With High Efficiency Motor Furnaces<sup>1</sup> (Continued)**

UNIT MODEL	FURNACE		COIL MODEL <sup>2</sup>	COOLING				
	MODEL	WIDTH		RATED CFM	NET MBH		SEER	EER
					TOTAL	SENS.		
TCHE48S41S	TM8Y100C16MP11	21.0	FC49D	1400	46.0	34.0	14.75	12.25
TCHE48S41S	TM8Y100C20MP11	21.0	FC49D	1425	46.5	34.6	15.10	12.50
TCHE48S41S	TM8Y120C20MP11	21.0	FC49D	1425	46.5	34.6	15.10	12.50
TCHE48S41S	TM9E080C16MP11	21.0	FC49D	1425	46.0	34.4	14.25	11.75
TCHE48S41S	TM9E100C16MP11	21.0	FC49D	1425	46.0	34.4	14.25	11.75
TCHE48S41S	TM9E100C20MP11	21.0	FC49D	1400	46.0	34.0	15.00	12.50
TCHE48S41S	TM9E120D20MP11	24.5	FC49D	1400	46.5	34.4	15.10	12.50
TCHE48S41S	TM9V100C20MP11	21.0	FC49D	1350	46.0	33.6	14.75	12.25
TCHE48S41S	TM9V120D20MP11	24.5	FC49D	1375	46.0	33.8	15.10	12.50
TCHE48S41S	TM9Y080C16MP11	21.0	FC49D	1425	46.0	34.4	14.25	11.75
TCHE48S41S	TM9Y100C16MP11	21.0	FC49D	1425	46.0	34.4	14.25	11.75
TCHE48S41S	TM9Y100C20MP11	21.0	FC49D	1400	46.0	34.0	15.00	12.50
TCHE48S41S	TM9Y120D20MP11	24.5	FC49D	1400	46.5	34.4	15.10	12.50
TCHE48S41S	TMLV080C16MP11	21.0	FC49D	1425	46.0	34.4	14.25	12.00
TCHE48S41S	TMLV100C16MP11	21.0	FC49D	1425	46.0	34.4	14.25	12.00
TCHE48S41S	TMLV100C20MP11	21.0	FC49D	1425	46.0	34.2	15.00	12.50
TCHE48S41S	TMLV120C20MP11	21.0	FC49D	1425	46.0	34.2	15.00	12.50
TCHE48S41S	TMLX080C16MP11	21.0	FC49D	1400	46.0	34.0	14.75	12.25
TCHE48S41S	TMLX100C16MP11	21.0	FC49D	1400	46.0	34.0	14.75	12.25
TCHE48S41S	TMLX100C20MP11	21.0	FC49D	1425	46.5	34.6	15.10	12.50
TCHE48S41S	TMLX120C20MP11	21.0	FC49D	1425	46.5	34.6	15.10	12.50
TCHE48S41S	TP9C100C20MP12	21.0	FC49D	1350	46.0	33.6	14.75	12.25
TCHE48S41S	TP9C120D20MP12	24.5	FC49D	1375	46.0	33.8	15.10	12.50
TCHE48S41S	TPLC080C16MP12	21.0	FC49D	1425	46.0	34.4	14.25	12.00
TCHE48S41S	TPLC100C16MP12	21.0	FC49D	1425	46.0	34.4	14.25	12.00
TCHE48S41S	TPLC100C20MP12	21.0	FC49D	1425	46.0	34.2	15.00	12.50
TCHE48S41S	TPLC120C20MP12	21.0	FC49D	1425	46.0	34.2	15.00	12.50
TCHE48S41S	YP9C100C20MP12	21.0	FC49D	1350	46.0	33.6	14.75	12.25
TCHE48S41S	YP9C120D20MP12	24.5	FC49D	1375	46.0	33.8	15.10	12.50
TCHE48S41S	YPLC080C16MP12	21.0	FC49D	1425	46.0	34.4	14.25	12.00
TCHE48S41S	YPLC100C16MP12	21.0	FC49D	1425	46.0	34.4	14.25	12.00
TCHE48S41S	YPLC100C20MP12	21.0	FC49D	1425	46.0	34.2	15.00	12.50
TCHE48S41S	YPLC120C20MP12	21.0	FC49D	1425	46.0	34.2	15.00	12.50

For rated condition information, see the footnotes below the System Capacity - Single Piece and Modular Air Handlers table.

1. High Efficiency Motor Furnaces have B.O.D (Blower Off Delay) standard.
2. CM coils available with a factory installed horizontal drain pan. See price pages for specific model number.  
PSC furnaces, such as the TG8S, TGLS, and TG9S, use Coil Only Ratings.

## APPLICATIONS AND ACCESSORIES

Refer to Price Manual for specific model numbers.

Standard Application Limits*		
Maximum Lineset Equivalent Length	200 Ft	
Outdoor Ambient Temperature Limits		
Cooling Operation	Maximum DB	120°F
	Minimum DB	50°F

\* For Low Ambient and/or Long Lineset Applications, please see the accessories listed below.

**Non-Standard Lineset Applications** - For installations with reduced diameter or long linesets, refer to the current version of the Piping Application Guide P/N 247077, available in the Application Bulletins section on [www.upgnet.com](http://www.upgnet.com).

**OD Unit Anti Short Cycle Kit (10 Pack) S1-2TD08700124BK:** A time delay that prevents rapid compressor restarting as a result of power interruption, limit switch operation, or thermostat resetting. Not required for HP models, or for AC models with factory electronic controls.

**Standard Low Ambient Control Kit S1-2LA06700424:** Allows the use of air conditioning at low outdoor ambient temperatures down to +20°F (-7°C). For use with all R-410A single stage AC & HP models.

**Advanced Low Ambient Control Kit S1-2LA04701024:** Contains the necessary components and controls to allow cooling operation down to -20°F (-29°C). For use with all R-410A single stage AC & HP models.

**Low Pressure Switch Kit S1-2PS06700524:** Provides field installed low pressure (loss of charge) protection. Not required for HP models, or for AC models with factory electronic controls.

**High Ambient Condenser Fan Motor S1-FHM\*\*\*\*HT:** Class F 70°C motor to allow cooling operation up to 160°F air entering the condenser. For use with all R-410A single stage AC & HP models containing R-410A refrigerant only.

**Outdoor Communicating Board Kit (S1-33102952310):** Electronic control upgrade for standard AC & HP units to provide compatibility with the Residential Touch Screen Communicating Control.

**Start Assist Kit S1-2SA067\*\*\*\*:** Provides increased compressor starting torque for areas with low supply voltage. Required for units with recip compressors when applied with indoor TXV, and for all units when applied with long linesets or low ambient kits. May be factory installed on select AC & HP units (see Physical & Electrical Table). See Price Pages or Source1 SmartSearch for the correct kit for each application.

**Compressor Crankcase Heater Kit (S1-025\*\*\*\*):** A wrap-around electrical resistance heater that warms the compressor sump, reducing the chance of liquid slugging on startup. Required on all long lineset and low ambient applications. See Price Pages or Source1 SmartSearch for the correct part for each application.

**Indoor Blower-Off Delay Kit S1-2FD06700224:** Provides a 1-minute blower-off delay at the end of the cooling cycle. May be required for retrofits with non-Johnson Controls Unitary Products indoor units. This feature is factory-provided on all JCUP indoor products.

**Indoor TXV Kit S1-1TVM\*\*\*:** Thermal expansion valves precisely meter refrigerant for optimum performance over a wide range of conditions. See System Charge Table, Price Pages, or Source1 Smart Search for TXV part number for each AC & HP model.

**Cold Weather Charging Tent S1-CHGTENT01:** Provides warm environment to accurately service AC & HP systems in ambient conditions 55°F (13°C) or colder.

**Touch-up Paint S1-5130153\*\*\*\*:** Color matched aerosol paint for touching up unit chassis and panels. See Price Pages or Source1 SmartSearch for the correct color for each application.

**Compressor Sound Blanket S1-01007xxx000:** A field installed dense foam cover that provides 2dBA sound level reduction. See Price Pages or Source1 SmartSearch for the correct blanket for each application.

**Thermostat** - Compatible thermostat controls are available through accessory sourcing. For optimum performance, these outdoor units are fully compatible with the York Hx™ Touch-screen Thermostat (S1-THXU280\*) available through Source1. For more information, see the thermostat section of the Product Equipment Catalog.

## SOUND POWER RATINGS

Cooling	Octave Band Sound Power Level (db re. 1-pW)									
	Model Number	63	125	250	500	1000	2000	4000	8000	dBA
TCHE24S41S1	73	78	69	67	65	60	57	58	70	19.1
TCHE36S41S1	74	77	68	67	66	61	58	58	71	19.1
TCHE48S41S1	75	81	70	68	66	61	58	58	72	19.0

Rated in accordance with ARI Standard 270.

## MECHANICAL SPECIFICATIONS

### MANUFACTURE AND CERTIFICATIONS

- Units shall be manufactured in an ISO 9001 certified facility.
- Units shall be certified by CSA to UL 1995 / CSA 22.2 and performance certified to ANSI/AHRI Standard 210/240.
- Units shall be sound tested according to ANSI/AHRI Standard 270.
- Certified matched system ratings will be available for download from the AHRI online directory at [www.ahridirectory.org](http://www.ahridirectory.org)
- Unit packaging shall be marked, "Assembled in the USA"

### UNIT APPLICATION

- Units shall be approved for cooling operation between 50°F and 120°F without modification.
- Units shall be approved for linesets up to 200 feet equivalent length without modification.
- Units shall be approved for installation within 6 inches of a flat vertical wall without modification, according to the instructions in the technical literature.
- Units shall be certified for seismic applications in accordance with CBC 2007 and IBC 2006.
- Units shall be designed to 72dBA or less to minimize sound pollution.

### UNIT ACCESS

- Units shall have a fan guard that can be removed independently of the cabinet for access to the condenser coil.
- Units shall have blow-through airflow for the condensing coil.
- Units shall have a separate compartment for electrical controls that can be accessed without disturbing the unit airflow.

### UNIT CONSTRUCTION

- Units shall be shipped completely wired, piped and assembled. Wiring pigtails shall be provided for field control wiring connections. Service valves shall be provided for field refrigerant line connections.
- Units shall be factory leak checked, run tested, and shipped with a holding charge of R-410A refrigerant.
- Unit cabinet components shall be G90 equivalent steel finished with powder-coat paint rated at a minimum of 1,000 hours under ASTM B117 testing.
- Unit base pan shall be stamped G90 equivalent steel finished with powder-coat paint rated at a minimum of 1,000 hours under ASTM B117 testing.
- Units shall have a factory installed spun copper filter-drier for faster installation and improved system reliability.
- Units shall be constructed with a high pressure switch and a low pressure switch for system protection.

### UNIT COMPONENTS

- Compressor shall be hermetic with internal electrical overload protection and internal overpressure protection.
- Compressor shall be mounted on rubber vibration isolators that do not require the removal of transportation clips or brackets.
- Units shall be constructed with scroll compressors.
- Condenser fan shall be direct drive with horizontal air discharge.
- Condenser fan shall be direct drive with swept-wing blades for low sound levels.
- Condenser coil shall be air cooled and constructed of zinc-coated aluminum microchannel construction for small size and low weight.

### UNIT WARRANTIES

- Unit manufacturer shall provide a 10-Year compressor warranty without a requirement for unit registration.
- Unit manufacturer shall provide a 5-Year parts warranty without a requirement for unit registration.

**TYPICAL INSTALLATION**

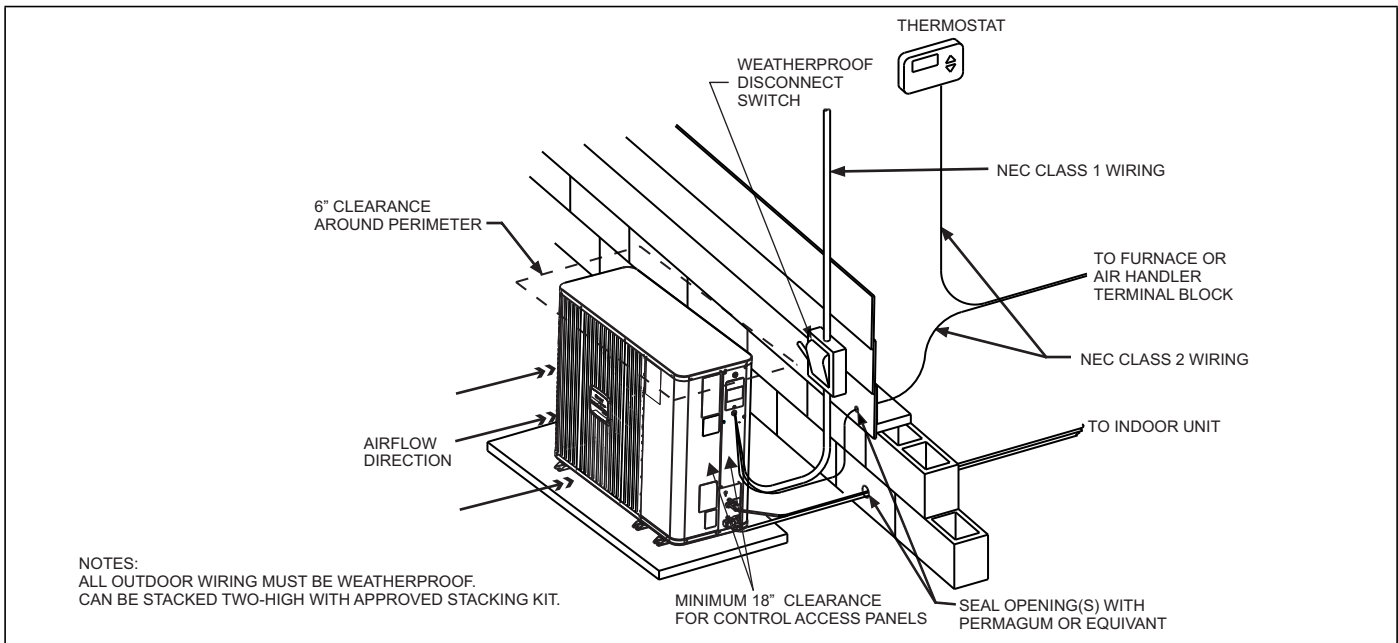

**MOUNTING HOLE GRAPHIC**

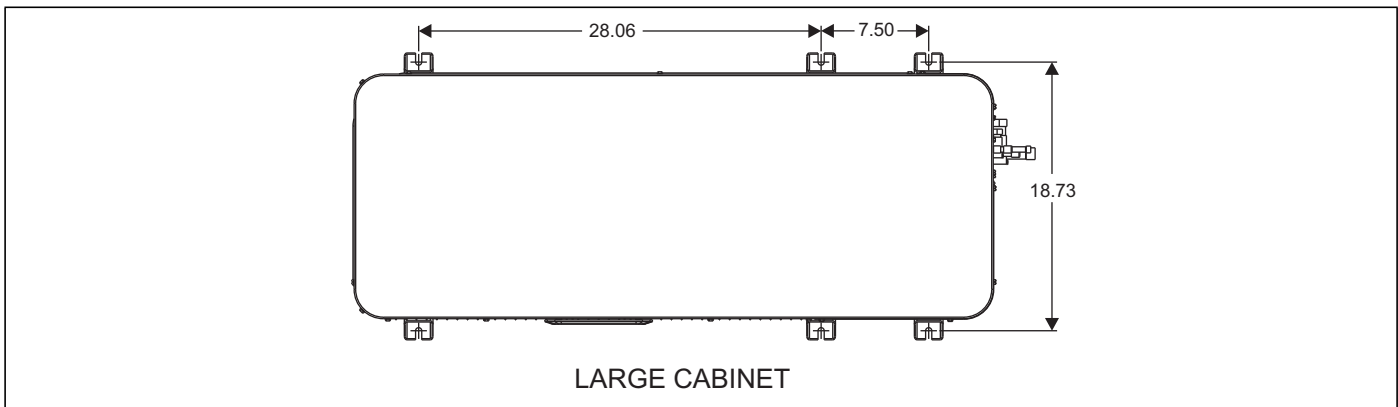

**TYPICAL FIELD WIRING**

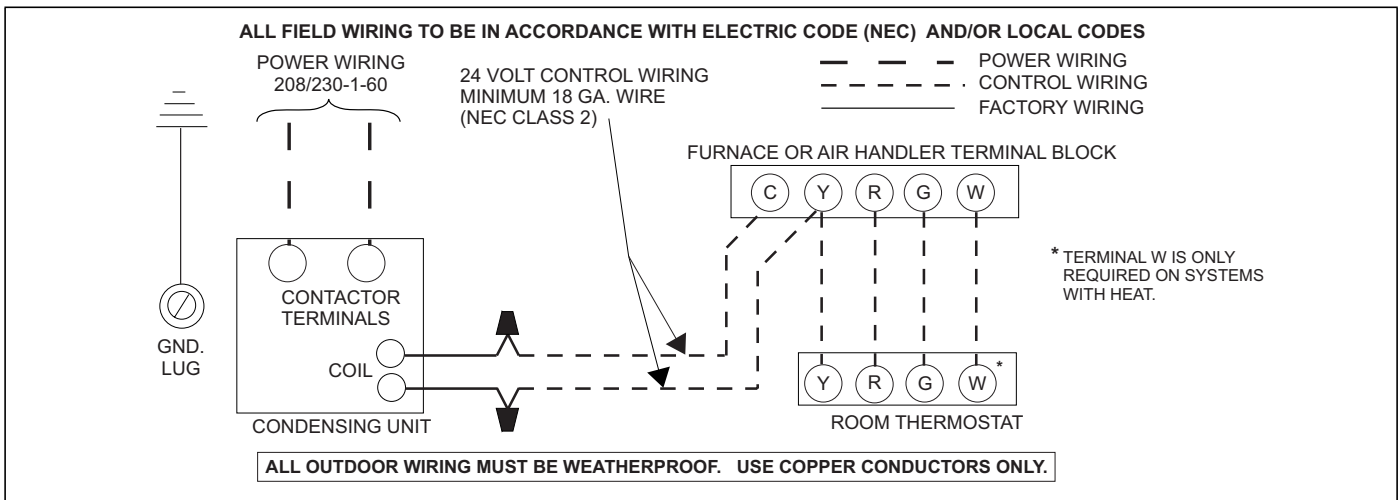

## PERFORMANCE DATA - 2 TON

CONDENSER-ONLY DATA (OUTDOOR UNIT)																		
MODEL	SATURATED SUCTION @ COMPRESSOR		Outdoor Ambient Temperature															
			55 °F		65 °F		75 °F		85 °F		95 °F		105 °F		115 °F		120 °F	
	T (°F)	P (PSIG)	MBH	KW	MBH	KW	MBH	KW	MBH	KW	MBH	KW	MBH	KW	MBH	KW	MBH	KW
TCHE24S41S1	35	107	22.3	2.31	21.2	2.36	20.1	2.36	19.0	2.36	17.8	2.36	16.5	2.36	15.1	2.36	14.4	2.36
	40	118	24.6	2.34	23.5	2.34	22.2	2.34	21.0	2.34	19.6	2.34	18.2	2.34	16.8	2.34	16.0	2.34
	45	130	27.2	2.33	25.8	2.33	24.5	2.33	23.1	2.33	21.6	2.33	20.1	2.33	18.6	2.33	17.8	2.33
	50	142	29.9	2.32	28.4	2.32	26.9	2.32	25.4	2.32	23.8	2.32	22.2	2.32	20.5	2.32	19.7	2.32
	55	156	32.8	2.22	31.1	2.31	29.5	2.31	27.8	2.31	26.1	2.31	24.3	2.31	22.5	2.31	21.6	2.31

## Notes:

- For Outdoor Unit (Condenser) performance only. Data does not include the effects of air handler power or heat.
- Performance based on 15°F subcooling and 15°F superheat at the Outdoor Unit base valves.
  - Increase capacity by 1% for each 2°F increase in subcooling.
  - Decrease capacity by 1% for each 2°F decrease in subcooling.
- Maximum recommended condensing temperature is 140°F.

COOLING PERFORMANCE DATA																		
AIR CONDITIONER MODEL NO.		TCHE24S41S1																
INDOOR COIL MODEL NO.		CF/CM/CU30B																
AIR TEMP. ENTERING OUTDOOR UNIT (°F)	IDCFM	600					800					1000						
	ID DB (°F)	80	80	75	80	80	80	80	75	80	80	80	80	80	75	80	80	
	ID WB (°F)	57	62	62	67	72	57	62	62	67	72	57	62	62	67	72	57	62
55	T.C.	22.0	24.2	30.2	26.6	27.5	23.6	25.3	28.1	27.1	28.2	25.3	26.3	26.0	27.5	28.9		
	S.C.	22.0	20.2	17.6	17.2	14.2	23.6	22.7	19.4	18.6	15.0	25.2	25.1	21.3	20.0	15.9		
	K.W.	1.32	1.32	1.65	1.36	1.31	1.39	1.39	1.55	1.41	1.39	1.46	1.46	1.46	1.46	1.46		
65	T.C.	24.6	23.6	26.5	25.8	27.4	24.6	24.6	25.9	26.5	28.2	24.7	25.5	25.3	27.2	29.0		
	S.C.	21.8	20.0	17.3	17.1	14.1	23.2	22.5	19.3	18.8	15.1	24.7	24.9	21.2	20.5	16.1		
	K.W.	1.68	1.44	1.61	1.46	1.43	1.63	1.52	1.60	1.52	1.51	1.58	1.59	1.58	1.58	1.59		
75	T.C.	27.2	22.9	22.8	24.9	27.3	25.6	23.9	23.7	25.9	28.2	24.1	24.8	24.7	26.9	29.1		
	S.C.	21.7	19.8	17.0	17.0	14.1	22.9	22.3	19.1	18.9	15.2	24.1	24.8	21.2	20.9	16.4		
	K.W.	2.04	1.57	1.57	1.57	1.56	1.87	1.64	1.64	1.64	1.63	1.71	1.71	1.71	1.71	1.71		
85	T.C.	23.4	21.9	21.9	24.1	26.4	23.4	22.9	22.8	25.1	27.2	23.4	24.0	23.7	26.0	28.0		
	S.C.	20.7	19.4	16.6	16.6	13.7	22.0	21.6	18.7	18.6	14.9	23.4	23.9	20.8	20.7	16.2		
	K.W.	1.98	1.74	1.74	1.74	1.71	1.93	1.81	1.81	1.81	1.79	1.87	1.88	1.88	1.88	1.87		
95	T.C.	19.7	20.9	21.0	23.4	25.5	21.2	22.0	21.8	24.3	26.2	22.7	23.1	22.7	25.2	27.0		
	S.C.	19.6	18.9	16.2	16.3	13.4	21.1	21.0	18.4	18.4	14.6	22.7	23.0	20.5	20.4	15.9		
	K.W.	1.92	1.92	1.92	1.92	1.87	1.98	1.98	1.99	1.98	1.95	2.04	2.05	2.05	2.05	2.04		
105	T.C.	18.6	19.6	19.6	22.0	24.0	20.0	20.6	20.4	22.8	24.7	21.5	21.7	21.2	23.6	25.5		
	S.C.	18.6	18.2	15.5	15.7	12.8	20.0	19.9	17.7	17.7	14.1	21.4	21.6	19.8	19.8	15.3		
	K.W.	2.22	2.21	2.20	2.23	2.19	2.29	2.28	2.27	2.29	2.26	2.36	2.36	2.33	2.35	2.33		
115	T.C.	17.6	18.3	18.3	20.6	22.6	19.0	19.3	19.1	21.4	23.3	20.3	20.3	19.8	22.1	24.0		
	S.C.	17.6	17.6	14.8	15.1	12.2	18.9	18.9	17.0	17.2	13.5	20.3	20.3	19.1	19.2	14.8		
	K.W.	2.52	2.49	2.47	2.54	2.50	2.59	2.58	2.54	2.60	2.56	2.66	2.66	2.60	2.65	2.62		
120	T.C.	16.6	17.1	17.0	19.2	21.1	17.9	18.0	17.7	19.9	21.8	19.1	19.0	18.4	20.6	22.5		
	S.C.	16.6	16.9	14.2	14.5	11.7	17.8	17.9	16.3	16.6	12.9	19.1	18.9	18.4	18.6	14.2		
	K.W.	2.82	2.77	2.75	2.85	2.81	2.89	2.87	2.81	2.90	2.86	2.96	2.96	2.88	2.95	2.90		

**NOTE:** ALL CAPACITIES INCLUDE INDOOR FAN HEAT. KW VALUES ARE FOR THE SYSTEM (OUTDOOR + INDOOR).

Green shaded cells are ACCA (TVA) conditions.

Blue shaded cells are AHRI conditions.

## Multipliers for determining the performance with other indoor sections.

**NOTE:** For dry bulb temperatures different than those listed (between 73-87 °F), sensible capacity increases by 1060 BTUH per 1000 CFM per degree above the listed temperature and decreases by 1060 BTUH per 1000 CFM per degree below the listed temperature.

**COIL MULTIPLIERS - 2 TON**

Air Handler	Coil	T.C.	S.C.	KW
-	CF/CM/CU30B	1.00	1.00	1.00
-	CF/CM/CU30C	0.98	1.03	0.98
-	CF/CM/CU30D	0.98	1.03	0.98
-	CF/CM36A	0.98	1.05	0.98
-	CF/CM/CU36B	0.98	1.05	0.98
-	CF/CM/CU36C	0.98	1.05	0.98
-	CF/CM/CU36D	0.98	1.05	0.98
-	CF42B	0.98	1.03	0.98
AE30BX21	-	1.00	1.05	0.96
AE36BX21	-	1.00	1.06	0.94
AE36CX21	-	1.00	1.07	0.94
AHE30B3X(H,T)21	-	1.00	1.04	0.96
AHE36C3X(H,T)21	-	1.00	1.07	0.94
AHV30B3X(H,T)21	-	1.00	1.04	0.96
AHV36C3X(H,T)21	-	1.00	1.02	0.94
AP30BX21	-	0.99	1.06	0.99
AVC30BX21	-	1.00	1.06	0.94
AVC36BX21	-	1.00	1.07	0.94
AVC36CX21	-	1.00	1.06	0.94
ME08BN21	CF/CM30B	1.00	1.06	0.96
ME08BN21	CF/CM36B	1.00	1.05	0.94
ME12BN21	CF/CM30B	1.00	1.06	0.96
ME12BN21	CF/CM36B	1.00	1.09	0.94
ME14DN21	CF/CM30D	1.00	1.06	0.94
ME14DN21	CF/CM36D	1.00	1.09	0.94
ME16CN21	CF/CM30C	1.00	1.06	0.98
ME16CN21	CF/CM36C	1.00	1.08	0.98
MVC08BN21	CF/CM30B	1.00	1.02	0.94
MVC08BN21	CF/CM36B	1.00	1.05	0.96
MVC12BN21	CF/CM30B	1.00	1.05	0.96
MVC12BN21	CF/CM36B	1.00	1.05	0.96
MVC14DN21	CF/CM30D	1.00	1.03	0.96
MVC14DN21	CF/CM36D	1.00	1.09	0.94
MVC16CN21	CF/CM30C	1.00	1.08	0.98
MVC16CN21	CF/CM36C	1.00	1.08	0.96

**FURNACE MULTIPLIERS - 2 TON**

Furnaces	Coil	T.C.	S.C.	KW
TM8V060A12MP11	CF/CM36A	1.00	1.05	0.96
TM8V080B12MP11	CF/CM/CU30B	1.00	1.05	0.96
TM8V080B12MP11	CF/CM/CU36B	1.00	1.05	0.96
TM8V080C16MP11	CF/CM/CU30C	1.00	1.09	0.98
TM8V080C16MP11	CF/CM/CU30D	1.00	1.09	0.98
TM8V080C16MP11	CF/CM/CU36C	1.00	1.10	0.96
TM8V080C16MP11	CF/CM/CU36D	1.00	1.11	0.96
TM8V100C16MP11	CF/CM/CU30C	1.00	1.09	0.98
TM8V100C16MP11	CF/CM/CU30D	1.00	1.09	0.98
TM8V100C16MP11	CF/CM/CU36C	1.00	1.10	0.96
TM8V100C16MP11	CF/CM/CU36D	1.00	1.11	0.96
TM8X060A12MP11	CF/CM36A	1.00	1.05	0.96
TM8X080B12MP11	CF/CM/CU30B	1.00	1.05	0.96
TM8X080B12MP11	CF/CM/CU36B	1.00	1.06	0.94
TM8X080C16MP11	CF/CM/CU30C	1.00	1.06	0.94
TM8X080C16MP11	CF/CM/CU30D	1.00	1.06	0.94

**FURNACE MULTIPLIERS - 2 TON (Continued)**

Furnaces	Coil	T.C.	S.C.	KW
TM8X080C16MP11	CF/CM/CU36C	1.00	1.09	0.94
TM8X080C16MP11	CF/CM/CU36D	1.00	1.09	0.94
TM8X100C16MP11	CF/CM/CU30C	1.00	1.06	0.94
TM8X100C16MP11	CF/CM/CU30D	1.00	1.06	0.94
TM8X100C16MP11	CF/CM/CU36C	1.00	1.09	0.94
TM8X100C16MP11	CF/CM/CU36D	1.00	1.09	0.94
TM8X100C20MP11	CF/CM/CU30C	0.99	1.04	0.99
TM8X100C20MP11	CF/CM/CU30D	1.00	1.06	1.00
TM8X100C20MP11	CF/CM/CU36C	0.99	1.08	0.99
TM8X100C20MP11	CF/CM/CU36D	1.00	1.09	1.00
TM8X120C20MP11	CF/CM/CU30C	0.99	1.04	0.99
TM8X120C20MP11	CF/CM/CU30D	1.00	1.06	1.00
TM8X120C20MP11	CF/CM/CU36C	0.99	1.08	0.99
TM8X120C20MP11	CF/CM/CU36D	1.00	1.09	1.00
TM8Y060A12MP11	CF/CM36A	1.00	1.05	0.96
TM8Y080B12MP11	CF/CM/CU30B	1.00	1.05	0.96
TM8Y080B12MP11	CF/CM/CU36B	1.00	1.06	0.94
TM8Y080C16MP11	CF/CM/CU30C	1.00	1.06	0.94
TM8Y080C16MP11	CF/CM/CU30D	1.00	1.06	0.94
TM8Y080C16MP11	CF/CM/CU36C	1.00	1.09	0.94
TM8Y080C16MP11	CF/CM/CU36D	1.00	1.09	0.94
TM8Y100C16MP11	CF/CM/CU30C	1.00	1.06	0.94
TM8Y100C16MP11	CF/CM/CU30D	1.00	1.06	0.94
TM8Y100C16MP11	CF/CM/CU36C	1.00	1.09	0.94
TM8Y100C16MP11	CF/CM/CU36D	1.00	1.09	0.94
TM8Y100C20MP11	CF/CM/CU30C	0.99	1.04	0.99
TM8Y100C20MP11	CF/CM/CU30D	1.00	1.06	1.00
TM8Y100C20MP11	CF/CM/CU36C	0.99	1.08	0.99
TM8Y100C20MP11	CF/CM/CU36D	1.00	1.09	1.00
TM8Y120C20MP11	CF/CM/CU30C	0.99	1.04	0.99
TM8Y120C20MP11	CF/CM/CU30D	1.00	1.06	1.00
TM8Y120C20MP11	CF/CM/CU36C	0.99	1.08	0.99
TM8Y120C20MP11	CF/CM/CU36D	1.00	1.09	1.00
TM9E040A10MP11	CF/CM36A	1.00	1.05	0.98
TM9E060B12MP11	CF/CM/CU30B	1.00	1.06	1.00
TM9E060B12MP11	CF/CM/CU36B	1.00	1.09	1.00
TM9E080B12MP11	CF/CM/CU30B	1.00	1.06	1.00
TM9E080B12MP11	CF/CM/CU36B	1.00	1.09	1.00
TM9E080C16MP11	CF/CM/CU30C	1.00	1.03	0.94
TM9E080C16MP11	CF/CM/CU30D	1.00	1.05	0.94
TM9E080C16MP11	CF/CM/CU36C	1.00	1.04	0.94
TM9E080C16MP11	CF/CM/CU36D	1.00	1.05	0.94
TM9E100C16MP11	CF/CM/CU30C	1.00	1.03	0.94
TM9E100C16MP11	CF/CM/CU30D	1.00	1.05	0.94
TM9E100C16MP11	CF/CM/CU36C	1.00	1.04	0.94
TM9E100C16MP11	CF/CM/CU36D	1.00	1.05	0.94
TM9E100C20MP11	CF/CM/CU30C	1.00	1.06	0.98
TM9E100C20MP11	CF/CM/CU30D	1.00	1.06	0.98
TM9E100C20MP11	CF/CM/CU36C	1.00	1.06	0.98
TM9E100C20MP11	CF/CM/CU36D	1.00	1.06	0.98
TM9E120D20MP11	CF/CM/CU30D	1.00	1.06	0.96
TM9E120D20MP11	CF/CM/CU36D	1.00	1.09	0.96
TM9V060B12MP11	CF/CM/CU30B	1.00	1.05	0.96
TM9V060B12MP11	CF/CM/CU36B	1.00	1.09	0.96



## FURNACE MULTIPLIERS - 2 TON (Continued)

Furnaces	Coil	T.C.	S.C.	KW
TM9V080B12MP11	CF/CM/CU30B	1.00	1.05	0.96
TM9V080B12MP11	CF/CM/CU36B	1.00	1.09	0.96
TM9V080C16MP11	CF/CM/CU30C	1.00	1.08	0.96
TM9V080C16MP11	CF/CM/CU30D	1.00	1.06	0.94
TM9V080C16MP11	CF/CM/CU36C	1.00	1.09	0.96
TM9V080C16MP11	CF/CM/CU36D	1.00	1.09	0.94
TM9V100C16MP11	CF/CM/CU30C	1.00	1.08	0.96
TM9V100C16MP11	CF/CM/CU30D	1.00	1.06	0.94
TM9V100C16MP11	CF/CM/CU36C	1.00	1.09	0.96
TM9V100C16MP11	CF/CM/CU36D	1.00	1.09	0.94
TM9Y040A10MP11	CF/CM36A	1.00	1.05	0.98
TM9Y060B12MP11	CF/CM/CU30B	1.00	1.06	1.00
TM9Y060B12MP11	CF/CM/CU36B	1.00	1.09	1.00
TM9Y080B12MP11	CF/CM/CU30B	1.00	1.06	1.00
TM9Y080B12MP11	CF/CM/CU36B	1.00	1.09	1.00
TM9Y080C16MP11	CF/CM/CU30C	1.00	1.03	0.94
TM9Y080C16MP11	CF/CM/CU30D	1.00	1.05	0.94
TM9Y080C16MP11	CF/CM/CU36C	1.00	1.04	0.94
TM9Y080C16MP11	CF/CM/CU36D	1.00	1.05	0.94
TM9Y100C16MP11	CF/CM/CU30C	1.00	1.03	0.94
TM9Y100C16MP11	CF/CM/CU30D	1.00	1.05	0.94
TM9Y100C16MP11	CF/CM/CU36C	1.00	1.04	0.94
TM9Y100C16MP11	CF/CM/CU36D	1.00	1.05	0.94
TM9Y100C20MP11	CF/CM/CU30C	1.00	1.06	0.98
TM9Y100C20MP11	CF/CM/CU30D	1.00	1.06	0.98
TM9Y100C20MP11	CF/CM/CU36C	1.00	1.06	0.98
TM9Y100C20MP11	CF/CM/CU36D	1.00	1.06	0.98
TM9Y120D20MP11	CF/CM/CU30D	1.00	1.06	0.96
TM9Y120D20MP11	CF/CM/CU36D	1.00	1.09	0.96
TMLV060A12MP11	CF/CM36A	1.00	1.05	0.96
TMLV080B12MP11	CF/CM/CU30B	1.00	1.05	0.96
TMLV080B12MP11	CF/CM/CU36B	1.00	1.05	0.96
TMLV080C16MP11	CF/CM/CU30C	1.00	1.09	0.98
TMLV080C16MP11	CF/CM/CU30D	1.00	1.09	0.98
TMLV080C16MP11	CF/CM/CU36C	1.00	1.10	0.96
TMLV080C16MP11	CF/CM/CU36D	1.00	1.11	0.96
TMLV100C16MP11	CF/CM/CU30C	1.00	1.09	0.98
TMLV100C16MP11	CF/CM/CU30D	1.00	1.09	0.98
TMLV100C16MP11	CF/CM/CU36C	1.00	1.10	0.96
TMLV100C16MP11	CF/CM/CU36D	1.00	1.11	0.96
TMLX060A12MP11	CF/CM36A	1.00	1.05	0.96
TMLX080B12MP11	CF/CM/CU30B	1.00	1.05	0.96
TMLX080B12MP11	CF/CM/CU36B	1.00	1.06	0.94
TMLX080C16MP11	CF/CM/CU30C	1.00	1.06	0.94
TMLX080C16MP11	CF/CM/CU30D	1.00	1.06	0.94
TMLX080C16MP11	CF/CM/CU36C	1.00	1.09	0.94
TMLX080C16MP11	CF/CM/CU36D	1.00	1.09	0.94
TMLX080C16MP11	CF/CM/CU36C	1.00	1.09	0.94
TMLX080C16MP11	CF/CM/CU36D	1.00	1.09	0.94
TMLX100C16MP11	CF/CM/CU30C	1.00	1.06	0.94
TMLX100C16MP11	CF/CM/CU30D	1.00	1.06	0.94
TMLX100C16MP11	CF/CM/CU36C	1.00	1.09	0.94
TMLX100C16MP11	CF/CM/CU36D	1.00	1.09	0.94
TMLX100C20MP11	CF/CM/CU30C	0.99	1.04	0.99
TMLX100C20MP11	CF/CM/CU30D	1.00	1.06	1.00
TMLX100C20MP11	CF/CM/CU36C	0.99	1.08	0.99

## FURNACE MULTIPLIERS - 2 TON (Continued)

Furnaces	Coil	T.C.	S.C.	KW
TMLX100C20MP11	CF/CM/CU36D	1.00	1.09	1.00
TMLX120C20MP11	CF/CM/CU30C	0.99	1.04	0.99
TMLX120C20MP11	CF/CM/CU30D	1.00	1.06	1.00
TMLX120C20MP11	CF/CM/CU36C	0.99	1.08	0.99
TMLX120C20MP11	CF/CM/CU36D	1.00	1.09	1.00
TP9C060B12MP12	CF/CM/CU30B	1.00	1.05	0.96
TP9C060B12MP12	CF/CM/CU36B	1.00	1.09	0.96
TP9C080B12MP12	CF/CM/CU30B	1.00	1.05	0.96
TP9C080B12MP12	CF/CM/CU36B	1.00	1.09	0.96
TP9C080C16MP12	CF/CM/CU30C	1.00	1.08	0.96
TP9C080C16MP12	CF/CM/CU30D	1.00	1.06	0.94
TP9C080C16MP12	CF/CM/CU36C	1.00	1.09	0.96
TP9C080C16MP12	CF/CM/CU36D	1.00	1.09	0.94
TP9C100C16MP12	CF/CM/CU30C	1.00	1.08	0.96
TP9C100C16MP12	CF/CM/CU30D	1.00	1.06	0.94
TP9C100C16MP12	CF/CM/CU36C	1.00	1.09	0.96
TP9C100C16MP12	CF/CM/CU36D	1.00	1.09	0.94
TPLC060A12MP12	CF/CM36A	1.00	1.05	0.96
TPLC080B12MP12	CF/CM/CU30B	1.00	1.05	0.96
TPLC080B12MP12	CF/CM/CU36B	1.00	1.05	0.96
TPLC080C16MP12	CF/CM/CU30C	1.00	1.09	0.98
TPLC080C16MP12	CF/CM/CU30D	1.00	1.09	0.98
TPLC080C16MP12	CF/CM/CU36C	1.00	1.10	0.96
TPLC080C16MP12	CF/CM/CU36D	1.00	1.11	0.96
TPLC100C16MP12	CF/CM/CU30C	1.00	1.09	0.98
TPLC100C16MP12	CF/CM/CU30D	1.00	1.09	0.98
TPLC100C16MP12	CF/CM/CU36C	1.00	1.10	0.96
TPLC100C16MP12	CF/CM/CU36D	1.00	1.11	0.96
YP9C060B12MP12	CF/CM/CU30B	1.00	1.05	0.96
YP9C060B12MP12	CF/CM/CU36B	1.00	1.09	0.96
YP9C080B12MP12	CF/CM/CU30B	1.00	1.05	0.96
YP9C080B12MP12	CF/CM/CU36B	1.00	1.09	0.96
YP9C080C16MP12	CF/CM/CU30C	1.00	1.08	0.96
YP9C080C16MP12	CF/CM/CU30D	1.00	1.06	0.94
YP9C080C16MP12	CF/CM/CU36C	1.00	1.09	0.96
YP9C080C16MP12	CF/CM/CU36D	1.00	1.09	0.94
YP9C100C16MP12	CF/CM/CU30C	1.00	1.08	0.96
YP9C100C16MP12	CF/CM/CU30D	1.00	1.06	0.94
YP9C100C16MP12	CF/CM/CU36C	1.00	1.09	0.96
YP9C100C16MP12	CF/CM/CU36D	1.00	1.09	0.94
YPLC060A12MP12	CF/CM36A	1.00	1.05	0.96
YPLC080B12MP12	CF/CM/CU30B	1.00	1.05	0.96
YPLC080B12MP12	CF/CM/CU36B	1.00	1.05	0.96
YPLC080C16MP12	CF/CM/CU30C	1.00	1.09	0.98
YPLC080C16MP12	CF/CM/CU30D	1.00	1.09	0.98
YPLC080C16MP12	CF/CM/CU36C	1.00	1.10	0.96
YPLC080C16MP12	CF/CM/CU36D	1.00	1.11	0.96
YPLC100C16MP12	CF/CM/CU30C	1.00	1.09	0.98
YPLC100C16MP12	CF/CM/CU30D	1.00	1.09	0.98
YPLC100C16MP12	CF/CM/CU36C	1.00	1.10	0.96
YPLC100C16MP12	CF/CM/CU36D	1.00	1.11	0.96

## PERFORMANCE DATA - 3 TON

CONDENSER-ONLY DATA (OUTDOOR UNIT)																		
MODEL	SATURATED SUCTION @ COMPRESSOR		Outdoor Ambient Temperature															
			55 °F		65 °F		75 °F		85 °F		95 °F		105 °F		115 °F		120 °F	
	T (°F)	P (PSIG)	MBH	KW	MBH	KW	MBH	KW	MBH	KW	MBH	KW	MBH	KW	MBH	KW	MBH	KW
TCHE36S41S1	35	107	33.3	3.24	31.8	3.24	30.2	3.24	28.6	3.24	26.9	3.24	25.0	3.24	23.0	3.24	21.9	3.24
	40	118	36.6	3.22	35.0	3.22	33.3	3.22	31.6	3.22	29.7	3.22	27.7	3.22	25.5	3.22	24.4	3.22
	45	130	40.1	3.20	38.4	3.20	36.7	3.20	34.8	3.20	32.8	3.20	30.6	3.20	28.3	3.20	27.0	3.20
	50	142	43.9	3.18	42.1	3.18	40.2	3.18	38.2	3.18	36.0	3.18	33.7	3.18	31.2	3.18	29.8	3.18
	55	156	47.8	3.09	45.9	3.16	43.9	3.16	41.8	3.16	39.4	3.16	36.9	3.16	34.3	3.16	32.9	3.16

## Notes:

- For Outdoor Unit (Condenser) performance only. Data does not include the effects of air handler power or heat.
- Performance based on 15°F subcooling and 15°F superheat at the Outdoor Unit base valves.
  - Increase capacity by 1% for each 2°F increase in subcooling.
  - Decrease capacity by 1% for each 2°F decrease in subcooling.
- Maximum recommended condensing temperature is 140°F.

COOLING PERFORMANCE DATA																
AIR CONDITIONER MODEL NO.		TCHE36S41S1														
INDOOR COIL MODEL NO.		FC38C														
AIR TEMP. ENTERING OUTDOOR UNIT (°F)	IDCFM	800					1000					1200				
	ID DB (°F)	80	80	75	80	80	80	80	75	80	80	80	80	75	80	80
	ID WB (°F)	57	62	62	67	72	57	62	62	67	72	57	62	62	67	72
55	T.C.	34.2	37.0	36.9	39.9	42.2	35.6	38.1	37.9	40.9	42.9	37.1	39.1	38.9	41.9	43.7
	S.C.	34.1	32.8	28.0	27.5	21.8	35.6	35.6	30.1	29.4	22.8	37.0	38.4	32.3	31.3	23.7
	K.W.	1.89	1.91	1.88	1.90	1.92	1.97	1.98	1.96	1.98	2.01	2.04	2.06	2.05	2.06	2.09
65	T.C.	33.2	35.8	35.8	38.8	41.5	34.7	36.9	36.8	39.8	42.3	36.2	37.9	37.7	40.8	43.1
	S.C.	33.2	32.1	27.6	27.3	21.8	34.7	34.8	29.9	29.4	22.9	36.2	37.6	32.2	31.5	24.1
	K.W.	2.07	2.10	2.07	2.08	2.08	2.15	2.17	2.15	2.16	2.17	2.22	2.24	2.22	2.23	2.25
75	T.C.	32.3	34.5	34.6	37.7	40.8	33.8	35.7	35.6	38.6	41.6	35.4	36.8	36.6	39.6	42.5
	S.C.	32.2	31.4	27.1	27.1	21.8	33.8	34.1	29.6	29.4	23.1	35.3	36.8	32.0	31.7	24.4
	K.W.	2.26	2.29	2.26	2.26	2.25	2.33	2.35	2.33	2.33	2.33	2.40	2.42	2.39	2.40	2.40
85	T.C.	31.4	33.5	33.2	36.3	39.4	32.9	34.6	34.1	37.2	40.2	34.3	35.7	35.0	38.1	41.0
	S.C.	31.4	31.1	26.5	26.5	21.2	32.8	33.4	29.0	28.9	22.7	34.3	35.6	31.4	31.3	24.1
	K.W.	2.50	2.54	2.52	2.51	2.49	2.57	2.60	2.58	2.58	2.57	2.64	2.67	2.65	2.65	2.65
95	T.C.	30.6	32.4	31.8	35.0	38.0	31.9	33.5	32.6	35.8	38.8	33.3	34.6	33.4	36.7	39.5
	S.C.	30.5	30.7	25.9	25.9	20.7	31.9	32.6	28.3	28.4	22.3	33.2	34.5	30.8	31.0	23.8
	K.W.	2.74	2.79	2.78	2.77	2.74	2.81	2.86	2.84	2.83	2.81	2.87	2.92	2.90	2.90	2.89
105	T.C.	29.3	30.9	30.2	33.2	36.2	30.6	32.0	30.9	34.0	36.9	32.0	33.2	31.7	34.8	37.6
	S.C.	29.2	29.7	25.1	25.2	20.1	30.6	31.4	27.5	27.7	21.6	31.9	33.2	30.0	30.2	23.2
	K.W.	3.17	3.20	3.21	3.14	3.08	3.19	3.23	3.25	3.19	3.15	3.22	3.26	3.29	3.25	3.22
115	T.C.	28.0	29.4	28.5	31.5	34.5	29.3	30.7	29.3	32.3	35.2	30.7	31.9	30.0	33.0	35.8
	S.C.	28.0	28.8	24.3	24.5	19.4	29.3	30.3	26.7	27.0	21.0	30.6	31.9	29.1	29.5	22.6
	K.W.	3.58	3.60	3.63	3.50	3.42	3.57	3.60	3.65	3.55	3.48	3.56	3.60	3.67	3.59	3.55
120	T.C.	26.8	27.9	26.9	29.8	32.8	28.1	29.3	27.6	30.5	33.4	29.4	30.6	28.3	31.2	34.0
	S.C.	26.7	27.8	23.5	23.9	18.8	28.0	29.2	25.9	26.3	20.4	29.3	30.6	28.3	28.8	22.0
	K.W.	4.00	4.00	4.04	3.87	3.75	3.95	3.96	4.05	3.90	3.82	3.90	3.93	4.05	3.92	3.88

NOTE: ALL CAPACITIES INCLUDE INDOOR FAN HEAT. KW VALUES ARE FOR THE SYSTEM (OUTDOOR + INDOOR).

Green shaded cells are ACCA (TVA) conditions.

Blue shaded cells are AHRI conditions.

## Multipliers for determining the performance with other indoor sections.

NOTE: For dry bulb temperatures different than those listed (between 73-87 °F), sensible capacity increases by 1060 BTUH per 1000 CFM per degree above the listed temperature and decreases by 1060 BTUH per 1000 CFM per degree below the listed temperature.

**COIL MULTIPLIERS - 3 TON**

Air Handler	Coil	T.C.	S.C.	KW
-	FC38C	1.00	1.00	1.00
ME16CN21	FC38C	1.01	1.00	0.95
MVC16CN21	FC38C	1.01	1.00	0.96

**FURNACE MULTIPLIERS - 3 TON**

Furnaces	Coil	T.C.	S.C.	KW
TM8V080C16MP11	FC38C	1.00	0.99	0.98
TM8V100C16MP11	FC38C	1.00	0.99	0.98
TM8V100C20MP11	FC38C	1.01	0.99	0.94
TM8V120C20MP11	FC38C	1.01	0.99	0.94
TM8X080C16MP11	FC38C	1.01	1.00	0.96
TM8X100C16MP11	FC38C	1.01	1.00	0.96
TM8X100C20MP11	FC38C	1.00	0.99	0.96
TM8X120C20MP11	FC38C	1.00	0.99	0.96
TM8Y080C16MP11	FC38C	1.01	1.00	0.96
TM8Y100C16MP11	FC38C	1.01	1.00	0.96
TM8Y100C20MP11	FC38C	1.00	0.99	0.96
TM8Y120C20MP11	FC38C	1.00	0.99	0.96
TM9E080C16MP11	FC38C	1.00	0.99	0.96
TM9E100C16MP11	FC38C	1.00	0.99	0.96
TM9E100C20MP11	FC38C	1.00	0.99	0.96
TM9V080C16MP11	FC38C	1.01	0.99	0.96
TM9V100C16MP11	FC38C	1.01	0.99	0.96
TM9V100C20MP11	FC38C	1.00	0.99	0.96
TM9Y080C16MP11	FC38C	1.00	0.99	0.96
TM9Y100C16MP11	FC38C	1.00	0.99	0.96
TM9Y100C20MP11	FC38C	1.00	0.99	0.96
TMLV080C16MP11	FC38C	1.00	0.99	0.98
TMLV100C16MP11	FC38C	1.00	0.99	0.98
TMLV100C20MP11	FC38C	1.01	0.99	0.94
TMLV120C20MP11	FC38C	1.01	0.99	0.94
TMLX080C16MP11	FC38C	1.01	1.00	0.96
TMLX100C16MP11	FC38C	1.01	1.00	0.96
TMLX100C20MP11	FC38C	1.00	0.99	0.96
TMLX120C20MP11	FC38C	1.00	0.99	0.96
TP9C080C16MP12	FC38C	1.01	0.99	0.96
TP9C100C16MP12	FC38C	1.01	0.99	0.96
TP9C100C20MP12	FC38C	1.00	0.99	0.96
TPLC080C16MP12	FC38C	1.00	0.99	0.98
TPLC100C16MP12	FC38C	1.00	0.99	0.98
TPLC100C20MP12	FC38C	1.01	0.99	0.94
TPLC120C20MP12	FC38C	1.01	0.99	0.94
YP9C080C16MP12	FC38C	1.01	0.99	0.96
YP9C100C16MP12	FC38C	1.01	0.99	0.96
YP9C100C20MP12	FC38C	1.00	0.99	0.96
YPLC080C16MP12	FC38C	1.00	0.99	0.98
YPLC100C16MP12	FC38C	1.00	0.99	0.98
YPLC100C20MP12	FC38C	1.01	0.99	0.94
YPLC120C20MP12	FC38C	1.01	0.99	0.94

## PERFORMANCE DATA - 4 TON

CONDENSER-ONLY DATA (OUTDOOR UNIT)																		
MODEL	SATURATED SUCTION @ COMPRESSOR		Outdoor Ambient Temperature															
			55 °F		65 °F		75 °F		85 °F		95 °F		105 °F		115 °F		120 °F	
	T (°F)	P (PSIG)	MBH	KW	MBH	KW	MBH	KW	MBH	KW	MBH	KW	MBH	KW	MBH	KW	MBH	KW
TCHE48S41S1	35	107	45.1	4.13	42.9	4.22	40.7	4.22	38.5	4.22	36.2	4.22	33.7	4.22	31.1	4.22	29.8	4.22
	40	118	49.5	4.20	47.0	4.20	44.7	4.20	42.3	4.20	39.9	4.20	37.2	4.20	34.4	4.20	33.0	4.20
	45	130	54.0	4.17	51.5	3.99	48.9	4.17	46.4	4.17	43.8	4.17	40.9	4.17	37.9	4.17	36.4	4.17
	50	142	58.8	4.14	56.1	4.05	53.4	4.14	50.6	4.14	47.8	4.14	44.9	4.14	41.7	4.14	39.9	4.14
	55	156	64.1	4.10	61.1	4.01	58.2	4.10	55.1	4.10	52.1	4.10	49.0	4.10	28.8	4.10	43.8	4.10

## Notes:

- For Outdoor Unit (Condenser) performance only. Data does not include the effects of air handler power or heat.
- Performance based on 15°F subcooling and 15°F superheat at the Outdoor Unit base valves.
  - Increase capacity by 1% for each 2°F increase in subcooling.
  - Decrease capacity by 1% for each 2°F decrease in subcooling.
- Maximum recommended condensing temperature is 140°F.

COOLING PERFORMANCE DATA																	
AIR CONDITIONER MODEL NO.		TCHE48S41S1															
INDOOR COIL MODEL NO.		FC49D															
AIR TEMP. ENTERING OUTDOOR UNIT (°F)	IDCFM	1225					1425					1625					
	ID DB (°F)	80	80	75	80	80	80	80	75	80	80	80	80	80	75	80	80
	ID WB (°F)	57	62	62	67	72	57	62	62	67	72	57	62	62	67	72	
55	T.C.	45.8	48.3	47.9	49.5	51.6	47.0	49.2	48.8	50.3	52.5	48.3	50.2	49.7	51.0	53.4	
	S.C.	44.9	40.0	34.6	31.9	26.4	46.1	42.0	36.0	33.0	27.2	47.4	43.9	37.4	34.1	28.0	
	K.W.	2.51	2.54	2.53	2.55	2.61	2.60	2.62	2.62	2.64	2.70	2.68	2.70	2.70	2.73	2.79	
65	T.C.	44.7	47.1	47.4	49.7	52.4	46.2	48.2	48.4	50.5	53.2	47.7	49.3	49.5	51.4	54.1	
	S.C.	43.8	40.3	34.7	32.8	27.0	45.3	42.9	36.6	34.3	28.0	46.8	45.5	38.5	35.7	29.0	
	K.W.	2.78	2.80	2.80	2.81	2.85	2.86	2.88	2.88	2.90	2.94	2.94	2.96	2.95	2.99	3.04	
75	T.C.	43.5	46.0	46.8	49.8	53.1	45.3	47.2	48.0	50.8	54.0	47.1	48.4	49.2	51.7	54.8	
	S.C.	42.7	40.6	34.7	33.7	27.6	44.5	43.9	37.2	35.6	28.8	46.2	47.1	39.6	37.4	30.0	
	K.W.	3.04	3.06	3.07	3.08	3.10	3.12	3.13	3.14	3.16	3.19	3.19	3.21	3.21	3.24	3.28	
85	T.C.	42.2	44.1	44.9	48.0	51.7	44.0	45.3	46.0	48.9*	52.6	45.7	46.4	47.2	49.9	53.4	
	S.C.	41.4	39.9	34.0	33.2	27.1	43.1	42.7	36.6	35.3	28.4	44.8	45.4	39.1	37.4	29.7	
	K.W.	3.41	3.43	3.44	3.44	3.45	3.48	3.50	3.52	3.52	3.54	3.55	3.58	3.60	3.60	3.63	
95	T.C.	40.9	42.2	43.0	46.1	50.3	42.6	43.3	44.1	47.1	51.2	44.3	44.4	45.2	48.0	52.0	
	S.C.	40.1	39.3	33.3	32.6	26.6	41.8	41.4	36.0	35.0	28.0	43.5	43.6	38.6	37.4	29.5	
	K.W.	3.77	3.80	3.82	3.80	3.81	3.84	3.87	3.90	3.87	3.89	3.91	3.94	3.98	3.95	3.98	
105	T.C.	39.0	40.2	40.8	44.1	48.2	40.8	41.5	42.0	45.0	49.0	42.5	42.9	43.1	45.9	49.9	
	S.C.	38.3	38.0	32.3	31.9	25.8	40.0	40.0	35.0	34.3	27.3	41.7	42.1	37.7	36.8	28.8	
	K.W.	4.34	4.40	4.43	4.32	4.30	4.38	4.42	4.49	4.39	4.38	4.42	4.44	4.54	4.45	4.45	
115	T.C.	37.2	38.2	38.7	42.1	46.1	39.0	39.8	39.9	43.0	46.9	40.8	41.4	41.1	43.9	47.8	
	S.C.	36.5	36.8	31.4	31.2	25.0	38.2	38.7	34.1	33.7	26.6	40.0	40.6	36.8	36.2	28.1	
	K.W.	4.89	4.97	5.03	4.84	4.78	4.90	4.95	5.06	4.89	4.85	4.91	4.92	5.09	4.94	4.92	
120	T.C.	35.4	36.2	36.6	40.1	44.0	37.2	38.1	37.8	41.0	44.8	39.0	40.0	39.0	41.9	45.6	
	S.C.	34.7	35.5	30.4	30.5	24.3	36.5	37.4	33.2	33.1	25.9	38.3	39.2	35.9	35.6	27.4	
	K.W.	5.44	5.55	5.62	5.35	5.26	5.42	5.48	5.63	5.39	5.32	5.40	5.40	5.63	5.42	5.38	

NOTE: ALL CAPACITIES INCLUDE INDOOR FAN HEAT. KW VALUES ARE FOR THE SYSTEM (OUTDOOR + INDOOR).

Green shaded cells are ACCA (TVA) conditions.

Blue shaded cells are AHRl conditions.

## Multipliers for determining the performance with other indoor sections.

NOTE: For dry bulb temperatures different than those listed (between 73-87 °F), sensible capacity increases by 1060 BTUH per 1000 CFM per degree above the listed temperature and decreases by 1060 BTUH per 1000 CFM per degree below the listed temperature.

**COIL MULTIPLIERS - 4 TON**

Air Handler	Coil	T.C.	S.C.	KW
-	FC49D	1.00	1.00	1.00
ME14DN21	FC49D	1.01	1.02	0.98
ME20DN21	FC49D	1.01	1.02	0.98
MVC14DN21	FC49D	0.99	0.94	0.94
MVC20DN21	FC49D	1.01	1.01	0.96

**FURNACE MULTIPLIERS - 4 TON**

Furnaces	Coil	T.C.	S.C.	KW
TM8V080C16MP11	FC49D	1.00	1.02	1.01
TM8V100C16MP11	FC49D	1.00	1.02	1.01
TM8V100C20MP11	FC49D	1.00	1.01	0.97
TM8V120C20MP11	FC49D	1.00	1.01	0.97
TM8X080C16MP11	FC49D	1.00	1.01	0.99
TM8X100C16MP11	FC49D	1.00	1.01	0.99
TM8X100C20MP11	FC49D	1.01	1.02	0.98
TM8X120C20MP11	FC49D	1.01	1.02	0.98
TM8Y080C16MP11	FC49D	1.00	1.01	0.99
TM8Y100C16MP11	FC49D	1.00	1.01	0.99
TM8Y100C20MP11	FC49D	1.01	1.02	0.98
TM8Y120C20MP11	FC49D	1.01	1.02	0.98
TM9E080C16MP11	FC49D	1.00	1.02	1.03
TM9E100C16MP11	FC49D	1.00	1.02	1.03
TM9E100C20MP11	FC49D	1.00	1.00	0.97
TM9E120D20MP11	FC49D	1.01	1.02	0.98
TM9V100C20MP11	FC49D	1.00	0.99	0.99

**FURNACE MULTIPLIERS - 4 TON (Continued)**

Furnaces	Coil	T.C.	S.C.	KW
TM9V120D20MP11	FC49D	1.00	1.00	0.97
TM9Y080C16MP11	FC49D	1.00	1.02	1.03
TM9Y100C16MP11	FC49D	1.00	1.02	1.03
TM9Y100C20MP11	FC49D	1.00	1.00	0.97
TM9Y120D20MP11	FC49D	1.01	1.02	0.98
TMLV080C16MP11	FC49D	1.00	1.02	1.01
TMLV100C16MP11	FC49D	1.00	1.02	1.01
TMLV100C20MP11	FC49D	1.00	1.01	0.97
TMLV120C20MP11	FC49D	1.00	1.01	0.97
TMLX080C16MP11	FC49D	1.00	1.01	0.99
TMLX100C16MP11	FC49D	1.00	1.01	0.99
TMLX100C20MP11	FC49D	1.01	1.02	0.98
TMLX120C20MP11	FC49D	1.01	1.02	0.98
TP9C100C20MP12	FC49D	1.00	0.99	0.99
TP9C120D20MP12	FC49D	1.00	1.00	0.97
TPLC080C16MP12	FC49D	1.00	1.02	1.01
TPLC100C16MP12	FC49D	1.00	1.02	1.01
TPLC100C20MP12	FC49D	1.00	1.01	0.97
TPLC120C20MP12	FC49D	1.00	1.01	0.97
YP9C100C20MP12	FC49D	1.00	0.99	0.99
YP9C120D20MP12	FC49D	1.00	1.00	0.97
YPLC080C16MP12	FC49D	1.00	1.02	1.01
YPLC100C16MP12	FC49D	1.00	1.02	1.01
YPLC100C20MP12	FC49D	1.00	1.01	0.97
YPLC120C20MP12	FC49D	1.00	1.01	0.97

# NOTES